

THE SWIMMING OF *NYMPHON GRACILE* (PYCONOGONIDA)

THE MECHANICS OF THE LEG-BEAT CYCLE

By ELFED MORGAN

*Department of Zoology and Comparative Physiology,
University of Birmingham*

(Received 11 December 1970)

INTRODUCTION

The arthropods illustrate a wide range of locomotory mechanisms, adapted to aquatic, terrestrial and aerial environments, and the problems of locomotion in these diverse habitats have attracted the attention of numerous investigators. Aspects of terrestrial locomotion have been extensively studied (Manton, 1953, 1958; Gray, 1968), especially in insects (Hughes, 1965; Wilson, 1966), while the aerodynamics of insect flight have been reviewed by Weis-Fogh & Jensen (1956) and by Pringle (1965). However, apart from Nachtigall's (1960, 1965) detailed investigation of the hydrodynamics of swimming in the freshwater beetles *Acilius* and *Gyrinus*, and Hughes's (1958) account of swimming in *Dytiscus*, reports of arthropod swimming mechanisms have been confined mainly to the crustacea and appear to have been largely descriptive (Lochhead, 1961). In comparison, patterns of locomotion in the pyconogonids, a relatively much smaller group, have been scarcely studied. These are mostly benthic marine organisms living attached to the coelentrates and bryozoans on which they feed, but some of the more delicate genera, notably *Anoplodactylus* and *Pallene* (Cole, 1901), and *Nymphon* sp. (Prell, 1910; Fage, 1932; Morgan, Nelson-Smith & Knight-Jones, 1964) have been reported swimming freely, propelling themselves through the water by means of the four pairs of walking legs. These beat mainly in a vertical plane, so the animal moves through the water dorsal side-first, rather like the spider crabs of the genus *Macropodia* (Hartnoll, 1960). In *N. gracile* the legs beat ventrally in a metachronal sequence, starting from the rear (Knight-Jones & Macfadyen, 1959), but apart from being longer and rather more slender than the legs of the relatively more massive genera they do not appear to be specialized for swimming as are the pereopods of the portunid crabs, for example (Schafer, 1954). This unusual method of swimming merited further investigation, and in this paper some aspects of the hydrodynamics of the swimming beat of *N. gracile* are considered while the swimming gait will be discussed in a later publication.

MATERIALS AND METHODS

Specimens of *Nymphon gracile* were collected at low water from Mumbles Point on the Gower peninsula and kept at a temperature of 10 °C in a marine aquarium at Birmingham. Immature specimens and adults of both sexes, including ovigerous males, were used and observations were made on intact animals only.

The morphology and mode of articulation of the legs were determined by direct observation of living animals, and from studies of the muscular organization in amputated legs mounted on a glass slide.

Details of the leg-beat cycle were derived from ciné films of *Nymphon* swimming freely in the water or stepping on the bottom of small glass aquaria. The animals were illuminated from above and filmed both from the side and from above against a graduated background at 18 frames/s. The films were analysed using a single-frame projector equipped with a frame counter, and the angular movements of the three major segments of the leg were measured with a protractor on the projected image of each successive frame over a series of leg beats, recording only from legs beating parallel to the focal plane of the camera. The small size of the third coxal segment made the degree of articulation of the femur difficult to measure accurately, and the angular movement of the femur was more conveniently recorded from changes in the dorsal angle θ (see Fig. 11), the angle between the longitudinal axis of the femur and the dorso-ventral body axis.

The movements of the leg were also recorded mechanically. The animals were held from above in fine forceps, between the third and fourth body segments, and the tip of one of the legs was attached to a spring, arranged so that the leg pulled mainly vertically downwards. A small flag attached to the spring partially interrupted a light beam directed on to a selenium cell, and a synchronized flash arrangement enabled the leg to be photographed at different phases of the leg-beat cycle.

The swimming speeds of unrestrained animals were recorded visually as they moved vertically in a rectangular tank 6 cm by 6 cm by 30 cm deep, and the leg-beat frequency was noted. The temperature of the water during all the experiments was approximately 17° C.

RESULTS

Morphology

In *Nymphon* the four pairs of locomotory appendages are symmetrically arranged about the body (Fig. 1). The ovigers, which in the males may bear egg masses, are extended obliquely downwards, and like the pedipalps and chelicerae make no obvious contribution to the swimming effort. Each remaining leg extends from a lateral prolongation of the body segment and is made up of eight segments terminating in a claw. The nomenclature adopted in the following account is that employed by Börner, (1903, in Helfer & Schlottke, 1935) and by Bouvier (1923), and the terms 'dorsal' and 'ventral' are used to indicate the direction of flexion of the more distal segment when the longitudinal axis of each joint lies parallel to the horizontal body axis. With the exception of coxa 2, which articulates laterally, all the leg segments move in a vertical plane, and the muscular organization at the joint is basically similar to the crustacean pattern (see Lochhead, 1961), with a pair of muscles arranged antagonistically in the plane of flexion. Coxa 1 moves both above and below the longitudinal axis of the joint and the levator and depressor muscles, which originate extrinsically in the lateral extension of the body segment, are equally developed. The adductor and abductor muscles of coxa 2, located laterally in the first coxa, are also equally proportioned. Coxa 3 and the femur articulate primarily in a dorsal arc during swimming, and the fan-

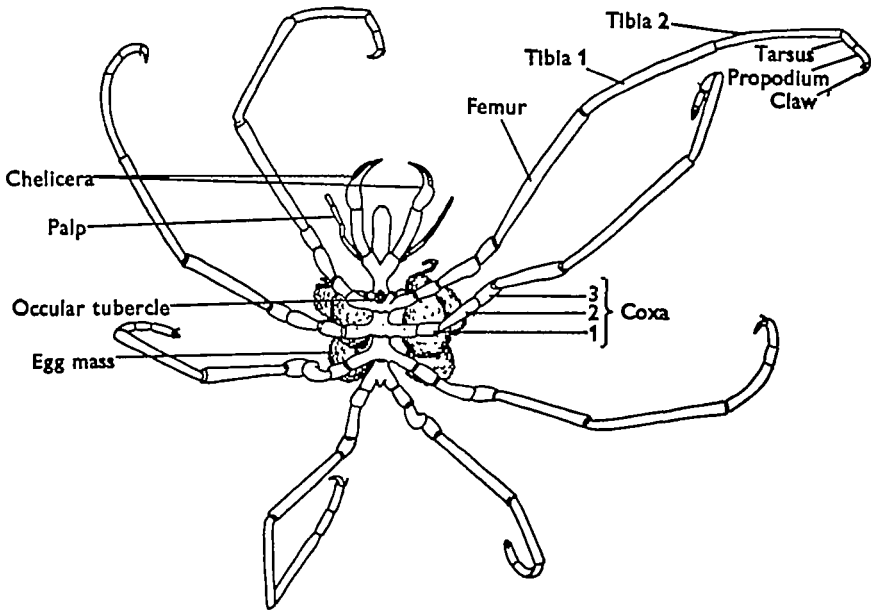

Fig. 1. Dorsal view of an ovigerous male *Nymphon gracile* showing the organization of the legs and body segments.

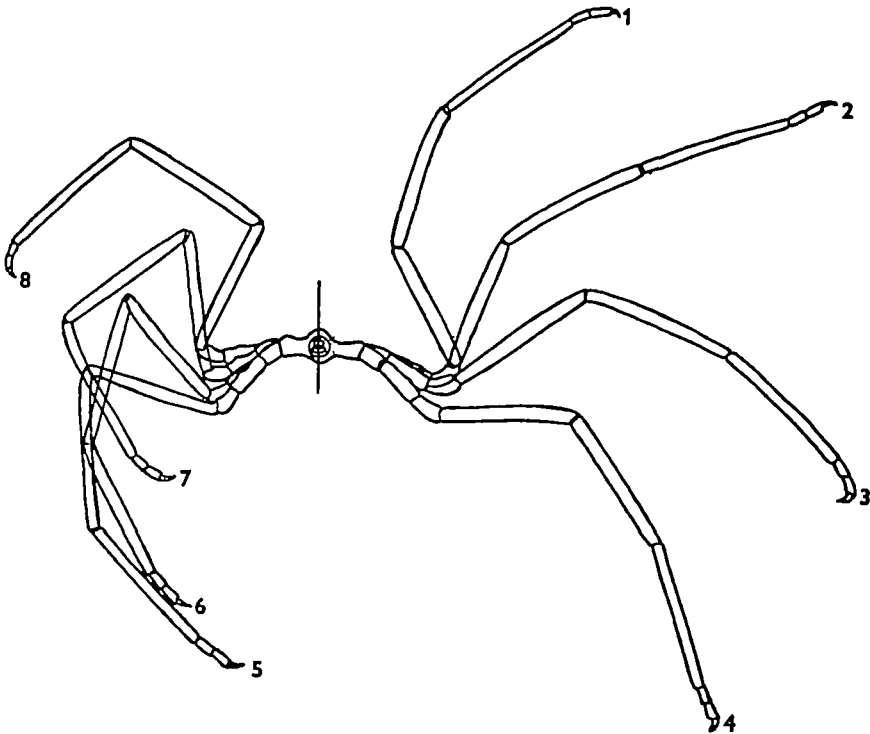

Fig. 2. Diagram illustrating the successive positions (1-8) taken up by the leg of *N. gracile* during the power stroke (right) and recovery phases (left) of the leg-beat cycle.

shaped levator muscles, which have their origins dorso-laterally in coxae 2 and 3 respectively, appear more powerful than their relatively slender antagonists.

In contrast it is the flexor (depressor) muscle of tibia 1 which is the larger, and the femoro-tibial joint permits flexion in a ventral arc only. Flexion of tibia 2 is similarly confined to a ventral arc but the operative muscles (located in tibia 1) now assume approximately equal proportions, and are rather longer and thinner than those of the more proximal leg segments.

The tarsus also flexes in a ventral arc and the flexor muscle is clearly evident, but this segment appears to lack an extensor muscle. The propodium articulates on the tarsus primarily in a dorso-ventral plane, and although containing the claw muscles it has no evident operative musculature of its own. Its movements during swimming are thus presumably entirely passive.

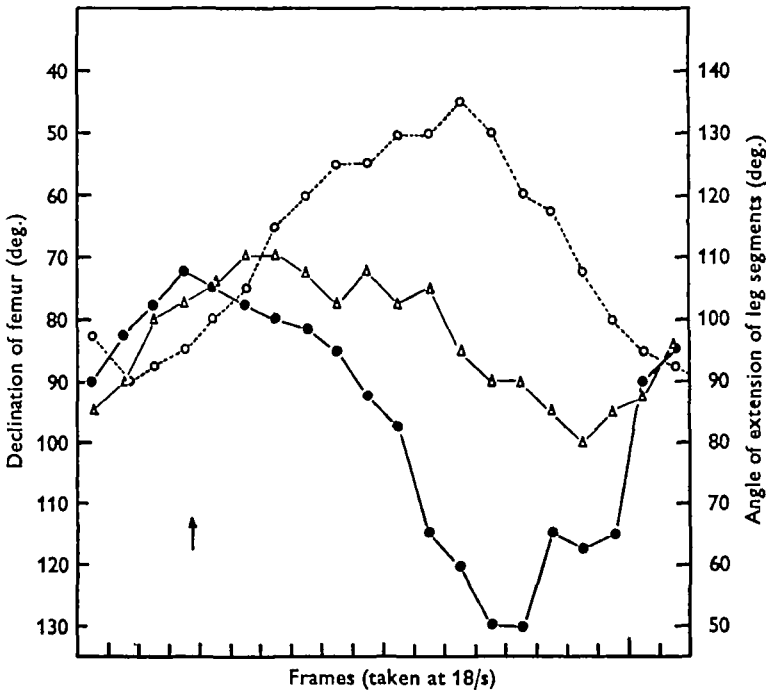

Fig. 3. The sequence of articulation of the three major segments of the leg of *N. gracile* during a single leg-beat cycle. The arrow indicates the start of the power stroke; ●, Angle of declination of femur from vertical; ▲, angle of femoro-tibial joint; ○, angle of joint between tibia 1 and tibia 2. Downward on graph represents down in water.

Leg-beat cycle

Each leg beats identically in a dorso-ventral plane, being extended during the power stroke and flexed during the recovery. The different positions taken up by the leg during the swimming beat are illustrated in Fig. 2. Articulation of the leg joints occurs in a fixed sequence distally (Fig. 3). At the start of the power stroke, as indicated by the start of the downward movement of the femur, tibia 1 was fully extended while the basal joint of tibia 2 was still opening out. Tibia 1 remained extended during most of the downstroke but started to bend near the end of the stroke. The degree of flexion,

which reaches its maximum during the recovery stroke, is greater when the leg beats through an arc of high elevation (Fig. 4), so the leg radius is still considerably lower during the recovery than during the power stroke. The onset of flexion of tibia 2 on tibia 1 was usually also delayed until the latter had closed through almost half its arc of travel, and this approximately coincided with the start of the upstroke (Fig. 3).

The extensions of tibia 1 and tibia 2 were also demonstrated using a semi-isometric recording system (see Methods). Tibia 1 starts to open out early during the recovery stroke, as indicated by the initial inflexion on the rising part of the trace shown in Fig. 5, while a similar, smaller inflexion occurring later indicates the extension of tibia 2. During the downstroke, however, the tip moves in a continuous arc, producing

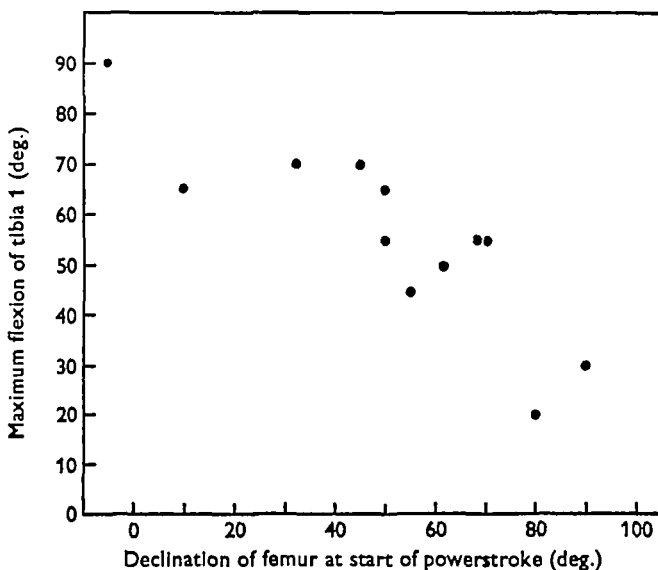

Fig. 4. Relationship between the extent of flexion of the femoro-tibial joint during the recovery phase and the declination of the femur at the start of the following power stroke.

a smooth downward deflexion. Slight lateral movements of the limbs, resulting from the contraction of the adductor and abductor muscles of coxa 2, usually occurred immediately prior to the downstroke, with the femur in the elevated position or, rather less frequently, at the beginning of the recovery.

In animals crawling on the bottom of the tank the legs flex in a similar sequence to that used in swimming, and if the claw now makes contact with a suitable substrate this flexion results in the animal being drawn towards the point of attachment. Without available anchorage, however, the leg-beat frequency varies considerably, and when striding slowly the movement of one or more of the legs is frequently arrested, apparently at random during the leg-beat cycle, so that an interval of varying duration is evident between successive beats. Prior to the onset of swimming, however, the legs beat more consistently and the relationship between the frequency of beat and the vertical swimming speeds of four adult, but non-reproductive *Nymphon* is shown in Fig. 6. The lowest frequency recorded for a swimming animal was 0.7 beats/sec and at lower frequencies the animals started to sink slowly through the water. The mean

leg-beat frequency while swimming at constant depth was approximately 1 beat/s, and cinematographic analysis indicated that the power stroke and recovery were of approximately equal duration, with a P/R ratio of $1.15 (\pm 0.35)$.

When the movements of a single leg were recorded mechanically (in a restrained animal) the effective downthrust was confined to about 25–30% of the actual leg-beat cycle, but the leg-beat frequency was now slightly higher than that normally recorded for animals swimming at constant depth. At frequencies above 1 beat/s the rate of ascent increased sharply with increasing frequency, but the possible relationship between the duration of the effective thrust and the speed of progression, as described



Fig. 5. Movements of a single leg of *N. gracile* recorded mechanically over a series of beats. The extensions of tibia 1 and tibia 2 (arrowed) are evident as successive inflexions during the recovery phase of most cycles. A downward movement of the trace represents downward movement of leg.

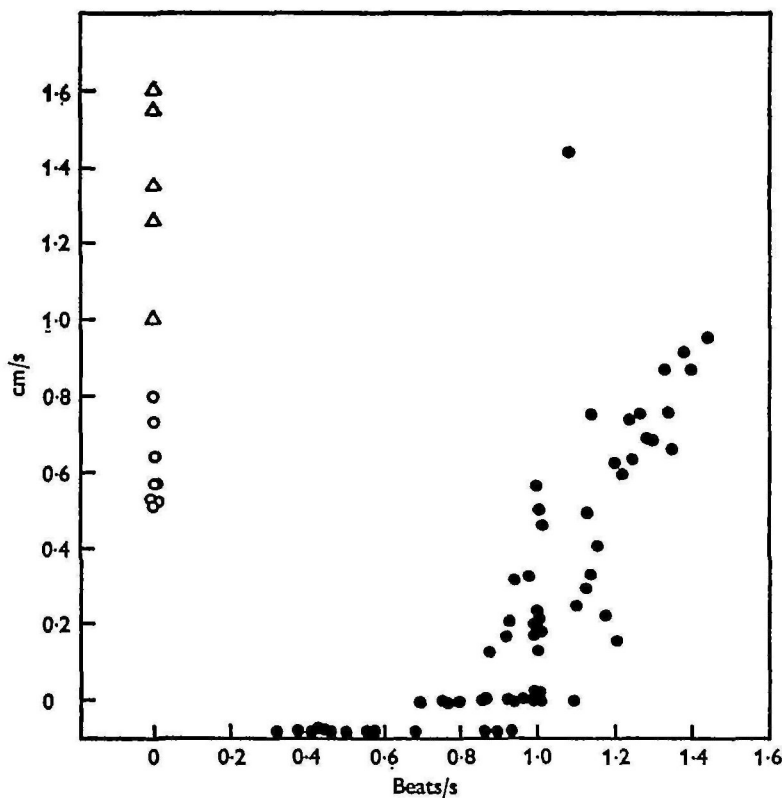

Fig. 6. Relationship between the vertical swimming speed and leg-beat frequency (●); the subzero points along the horizontal axis were recorded from animals striding on the bottom. The rates of sinking with legs extended (○); and in the 'plummeting' position (△); are indicated at zero beats/s.

Manton (1950, 1953) and Hughes (1952), has not been investigated here. Higher frequencies than those shown in Fig. 6 were occasionally observed, usually as the animal turned vertically in the water, when occasional beats at frequencies of up to 3 beats/s were recorded.

When sinking through the water the legs are extended horizontally and beat only occasionally as if to control the descent, but in addition *Nymphon* may frequently adopt a 'plummeting' posture (Prell, 1910; Morgan *et al.* 1964) with the legs folded dorsally, when the rate of sinking is more than doubled (Fig. 6).

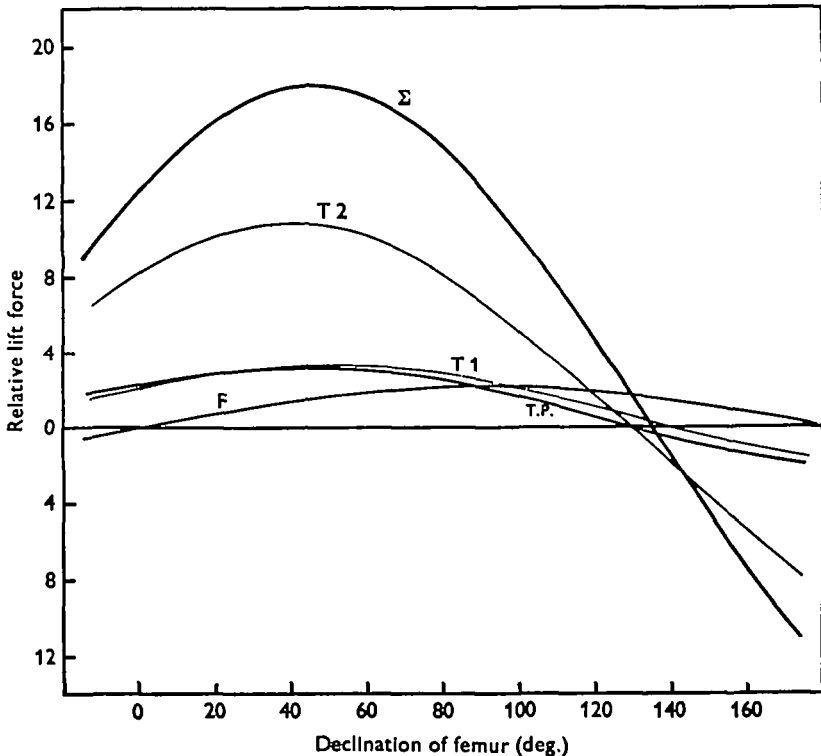

Fig. 7. Variation in relative lift exerted during the power stroke by different segments of the leg with declination of the femur, assuming consistent protraction and constant angular velocity. F = femur; T1 = tibia 1, T2 = tibia 2; T.P. = tarsus and propodium; Σ = total lift.

Mechanics of power stroke

In reaching an approximate value for the hydrodynamic forces during the power stroke a number of simplifications were made, since a more rigorous treatment seemed scarcely justified in the light of the many unknown or variable factors involved. The formula used and its justification are given in this Appendix.

The relative lift forces exerted by the different leg segments with the angles between the femur and tibia 1, and between tibia 1 and tibia 2, held constant at 140° and 170° respectively, and with the leg assumed to be moving at constant angular velocity, are plotted against the elevation of the femur in Fig. 7. The observed angular movement of the femur during swimming ranged from -10 to 170° . The leg gives greatest

overall lift when the femur was inclined at about 50° to the dorso-ventral body axis (i.e. $\theta = 50^\circ$). At greatest femur angles (i.e. decreasing elevation) the total lift generated decreases gradually to zero at about $\theta = 135^\circ$ and at still lower elevation negative lift values are obtained. In particular tibia 2 is responsible for the greater part of the lift, contributing more than half the maximum total force. This is the longest segment of the leg but has a smaller frontal area than either the femur or tibia 1. The maximum lift force due to tibia 2 alone occurs slightly earlier ($\theta = 40^\circ$) than the summated maximum for the whole leg, and falls to zero at about $\theta = 130^\circ$. The tarsus and the pro-

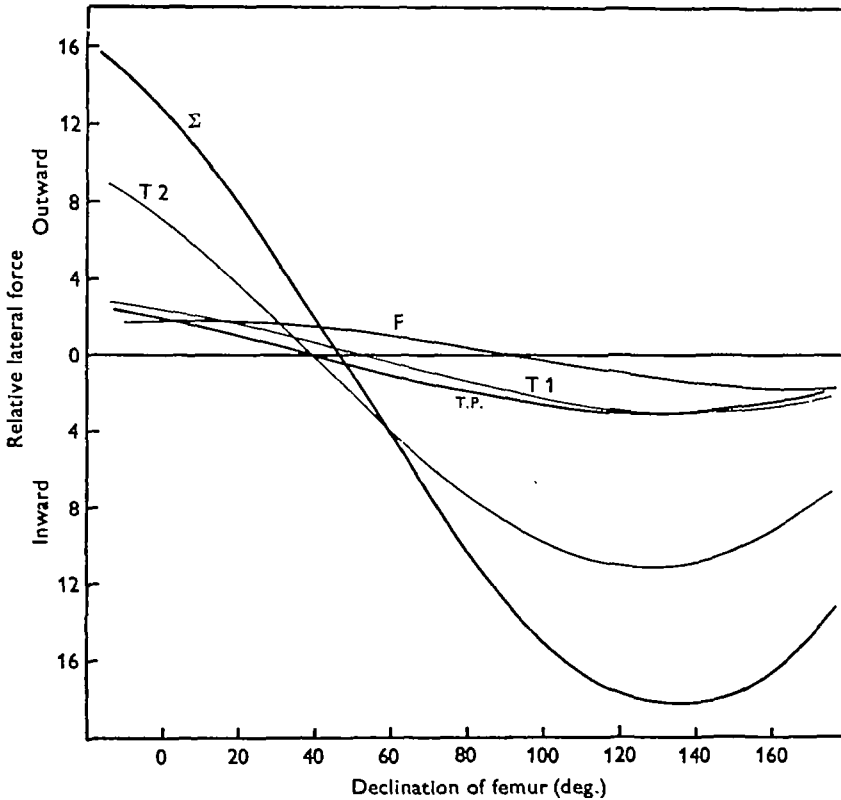

Fig. 8. Variation in the relative lateral thrust exerted during the power stroke by the different segments of the leg, assuming consistent protraction and constant angular velocity. Lettering as for Fig. 7.

podium have been considered together as a single linear extension of tibia 2 and their combined lift is found approximately to equal that of the larger but more centrally situated tibia 1, being about one-ninth of the maximum total force. Tibia 1, however, gives its greatest lift at slightly lower femur elevation. The lift force due to the femur is relatively small, being only about one-thirteenth of the maximum total force, although at low overall lift ($\theta = 130^\circ$) it may contribute more than three-quarters of the total. The femur continues to generate lift at even lower elevation but the overall lift force is now a negative one.

The lateral forces generated during the powerstroke are indicated in Fig. 8. At high

At femur elevation the total force is mainly an outward one, declining to zero at about $\theta = 50^\circ$. At lower elevation the lateral component is inwardly directed reaching a maximum at $\theta = 140^\circ$. The different segments of the leg contribute to the total lateral force in the same proportions as to the total lift. Tibia 2 is again responsible for the greater part of the force, and like the tarsus and propodium contributes an outward force at high femur elevation. The lateral force due to tibia 1 varies similarly with femur angle, reaching its zero, and subsequent maximum inward values, at only slightly lower elevations. In contrast the femur generates zero lateral force predictably at $\theta = 90^\circ$, giving an outward and inward thrust above and below this point respectively.

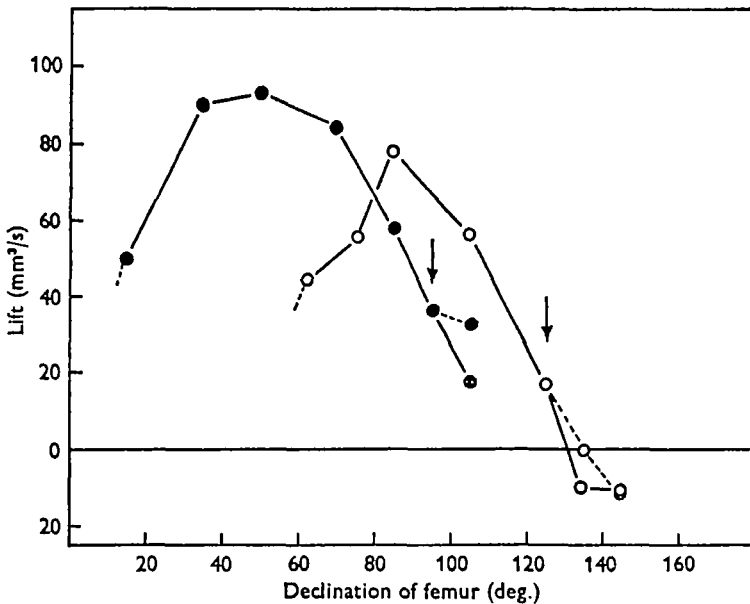

Fig. 9. Lift forces generated by the leg during the power stroke of two beats, approximately equal in amplitude and angular velocity, but of different elevation. The arrows indicate the onset of flexion of the femoro-tibial joint, and the dotted lines indicate the values obtained had the leg retained a constant profile.

During steady swimming successive leg beats were of approximately constant amplitude, but considerable variation existed both between individuals and between different swimming excursions of the same specimen, and the full arc of movement was rarely described completely. The angular velocity of the femur during the downstroke also varied, reaching a maximum on average half-way through the power stroke irrespective of elevation or amplitude of beat. When this is considered the hydrodynamic forces generated during the power stroke are found to vary with the elevation of the arc through which the femur moved. Fig. 9 shows the lift force generated during two independent beats of approximately equal amplitude and angular velocity, but of different elevation, calculated by substituting the actual velocity for ϕ in equation 1. Greater lift occurred during the high-elevation beat, where the arc of femur movement ranged from $\theta = -10$ to 110° . The maximum angular velocity of the femur now coincided with the limb profile which gave greatest vertical thrust

($\theta = 50^\circ$). During the low elevation beat on the other hand, angular velocity was greatest when the vertical thrust generated by the leg was only three-quarters of its potential maximum.

Tibia 2 remained fully extended throughout the downstroke in both cases, but tibia 1 started to flex late in each beat, thus imparting an additional velocity component to the more distal segments. (For details see Appendix.) This flexion reduced the vertical thrust generated in both cases, but the leg continued to provide lift throughout the power stroke at high femur elevation (Fig. 9), whereas when the arc of femur movement was lower, the vertical force acquired a negative value at the end of the power stroke. However, the angular velocity of the femur at this point is low, and the downward force generated is small in comparison to the total upthrust of the limb.

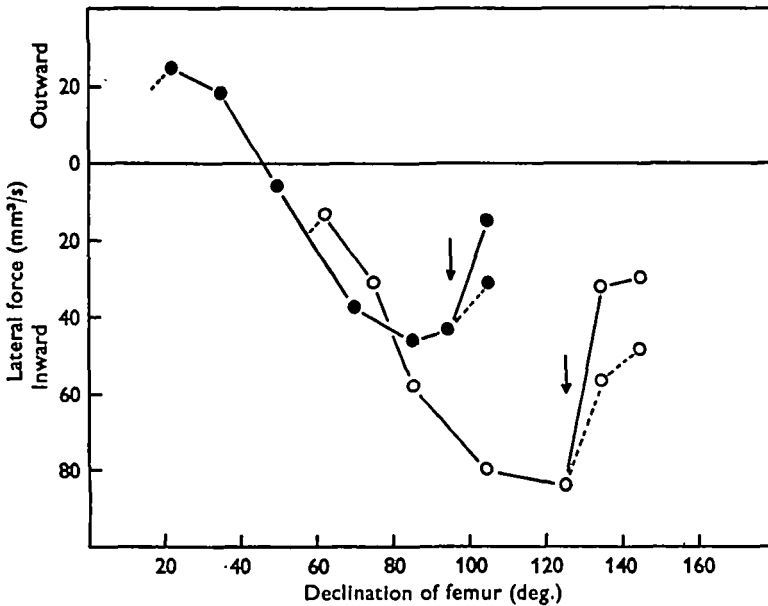

Fig. 10. Lateral forces generated by the leg during the power stroke of two beats, approximately equal in amplitude and angular velocity, but of different elevation. The arrows indicate the onset of flexion of the femoro-tibial joint, and the dotted lines indicate the values obtained had the leg retained a constant profile.

The lateral forces generated during the two beats are compared in Fig. 10. The lateral thrust is directed mainly inwards, even when the leg beats through the higher arc, but the maximum force developed is only half that of the lift. During the lower beat, however, the lift and lateral force (now directed entirely inward) are of approximately equal magnitude. Flexion of tibia 1 occurs when the inward force is already declining and reduces this component still further in both cases.

DISCUSSION

Prell's (1910) description of the leg-beat cycle, based on direct observation of swimming *Nymphon* without the benefit of cinematographic analysis, proved to be for the most part remarkably accurate. The angles between the major segments are

held constant with the leg in an almost completely extended position for most of the powerstroke so that the lift and lateral forces are generated mainly by the extrinsic muscles of the body segment, and by muscles located intrinsically in coxa 2 and coxa 3. However, because the joints are not completely extended, greatest lift is obtained with the femur inclined at about 50° to the vertical body axis, and the leg operates most efficiently while beating at high elevation when the maximum angular velocity of the femur coincides with the maximum lift profile. Tibia 2 contributes the greatest proportion of the lift at this point, and Prell concluded that 'podites 7-9', i.e. the tarsus, propodium and claw, take no part in swimming but are simply moved up and down, according to phase, by the water pressure. Although some dorsal bending of the terminal segments does occur, this reduces the frontal area of the leg only at high femur elevation. Later in the power stroke the frontal area and hence lift force would be increased, and for most of the effective beat the segments remain approximately horizontal, which is the position of maximum contribution to the lift. Considering the tarsus and propodium to be linear extensions of tibia 2, the combined lift force calculated for these two segments was found to equal that for tibia 1, and greatly exceeded that due to the femur. Moreover the actual lift force is probably higher than the calculated value, as the propodial spines and the claw were not considered during the calculation.

The high-elevation and low-elevation beats involve rather different combinations of lift and lateral forces. When the leg beats through an arc of high elevation the segments distal to and including tibia 1 continue to generate an upward force throughout the downstroke, even following flexion of the femoro-tibial joint (Fig. 9), so the total upwardly directed lift, as represented by the area beneath the graph, shows an increase of approximately 45% over that produced during the low-elevation beat. During the latter beat flexion of tibia 1 results in the leg giving a negative lift earlier than if it had retained a constant profile. Tibia 1 and the more distal segments are now moving in the opposite direction to the power stroke (a phenomenon rather similar to that described by Nachtigall (1960) for the water beetle *Acilius*), but their velocities are small when compared with the maximum velocity attained during the power stroke. Zero lateral force coincides with maximum lift, so that during the high-elevation beat the outward thrust at the start of the power stroke partly offsets the greater inwardly directed force developed later in the beat (Fig. 10).

During the recovery stroke there was no obvious relationship between the onset of flexion of the femoro-tibial joint and the elevation of the arc described by the femur, but the degree of closure attained is greater when the leg beats at high elevation (Fig. 3). Flexion of tibia 2 and of the terminal segments also occurs during the recovery so that the leg radius is reduced to only a little more than that of the largest leg segment. The drag on the leg during the recovery stroke is thus reduced considerably. Extension of tibia 2 begins late during the recovery, and is assisted in its final stages by the hydrodynamic resistance encountered at the start of the power stroke. Horizontal movement of the leg normally occurs at the start of the power stroke, with the femur in the elevated position when the angular velocity in the vertical plane is minimal. Throughout the remainder of the leg-beat cycle the joints articulate only in the vertical plane and there is evidently no marked rotation of any part of the limb as occurs in certain aquatic insects (Hughes, 1958; Nachtigall, 1960, 1965).

Prell relates how the swimming abilities of four sublittoral species of *Nymphal* varied according to the length of the tibial bristles, and describes how in *N. mixtum* these bristles are outspread during the power stroke but pressed close to the leg during the recovery (c.f. Dytiscidae (Wesenburg-Lund, 1913, in Nachtigall, 1965)). The swimming speeds of *N. gracile* (Fig. 6) compare favourably with the 1-1.5 cm/s reported for *N. mixtum* (Prell, 1910) but the tibial spines are sparse and very short, and their possible articulation in the manner described by Prell is difficult to ascertain. An increase in the rate of vertical ascent was generally achieved by increasing the leg-beat frequency, but occasionally unusually rapid upward excursions were recorded (see Fig. 6), suggesting that during most of the observations the swimming animals had considerable lift force in reserve. This would be especially significant for ovigerous males and might well be achieved by increasing the elevation of the arc of movement of each leg during the swimming cycle.

The rates of sinking, both with the legs extended and in the 'plummeting' position recorded here, are slightly lower than those previously reported (Morgan *et al.* 1964), but the present observations were made in shallower water (30 cm) and it is possible that the animals had not attained maximum sinking velocity. It may be noted, however, that to rise in the water as fast as the fall during passive sinking, the swimming-beat frequency is approximately double that required to maintain a stationary position, which is reasonable (Fig. 6).

SUMMARY

1. The organization of the swimming legs of *N. gracile* has been described. The legs beat ventrally so the animal swims with the dorsal side foremost. The joints between the major segments of the leg are extended for most of the power stroke, but the distal segments articulate sequentially later in the beat, commencing with the flexion of the femoro-tibial joint at the end of the power stroke. Continued flexion reduces the leg radius considerably during the recovery stroke.

2. Animals swimming at constant depth were found to have a leg-beat frequency of about 1 beat/s. Above this the rate of ascent increased rapidly with increasing frequency of beat. Abduction or adduction of the leg usually occurred prior to the start of the power stroke with the femur in the elevated position.

3. Assuming a fixed limb profile at constant angular velocity, maximum lift was calculated to have occurred with the femur inclined at an angle of about 50° to the dorso-ventral body axis. The outward component of the lateral thrust decreased to zero at this point, and with further declination of the femur the lateral forces became inwardly directed. Of the different segments of the leg, tibia 2 and the tarsus and propodium contribute most of the hydrodynamic force.

4. The angular velocity of the leg varied during the power stroke, and the actual forces generated during two beats having the same amplitude and angular velocity but of high and low elevation were calculated. Greater lift occurred during the high-elevation beat when the leg continued to provide lift throughout the power stroke, whereas the low-elevation beat acquired negative lift values towards the end of the power stroke. The lateral thrust was now directed entirely inwards.

APPENDIX

A small, approximately cylindrical object moving in a direction nearly perpendicular to its long axis is subject to drag forces proportional to its frontal area and its velocity. The dependence on velocity varies with the Reynolds number involved (see, for example, Alexander, 1968). The relationship is effectively linear for $Re < \text{about } 40$, whereas for values of $Re > 40$ drag varies with the square of the velocity. However, for *N. gracile* it is only the extreme tips of the legs at highest swimming speeds that exceed 10, and may reach 30.

The legs were assumed to be cylindrical, the femur and tibia 1 of diameter 0.5 mm, and tibia 2, tarsus and propodium 0.25 mm in diameter. These dimensions were approximately average for adult males of *N. gracile*. The existence of setae or other roughness was ignored. Only the femur moves perpendicularly to its length, all the other segments moving slightly diagonally. It was assumed that under these conditions

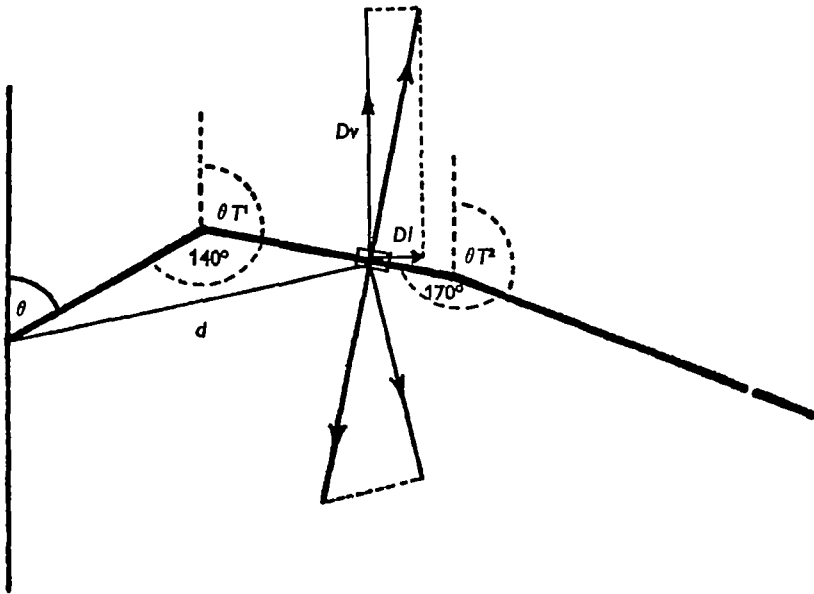

Fig. 11. Diagram illustrating the forces acting on a section of the leg of *N. gracile* during the power stroke, assuming a constant leg profile. For details see text.

the drag could be taken as the vector sum of the drag due to the perpendicular component of the velocity acting perpendicularly to the segment, and a longitudinal component proportional to the longitudinal component of the velocity. However, the drag on a long narrow cylinder moving end-on is very small, and since during the power stroke the leg segments moved mostly in a direction nearly perpendicular to their long axes, the longitudinal component was ignored.

The drag forces were therefore calculated for unit lengths of each of the leg segments, which were taken to be moving at constant velocity, namely their distance from the femur-coxa pivot (d) (see Fig. 11) multiplied by the angular velocity of the stroke. The unit drag (D) was therefore proportional to the component of this velocity perpendicular to the long axis of the segment concerned multiplied by the area of the unit,

and the total force on each segment was obtained by summation. Since these forces were acting in different directions for each segment, they were resolved into vertical and horizontal components and these finally were summed to give totals in the vertical axis (= lift Dv) and in the horizontal axis (= lateral force DI).

Assuming a constant leg profile, the drag on each segment of the leg was calculated from the equation:

$$D \text{ seg} = K \Sigma (ad\phi \cos \theta), \quad (1)$$

where a = frontal area, d = distance to femur-coxa pivot, ϕ = angular velocity of stroke, and θ = angle between segmental axes and the radius to femur-coxa pivot.

The flexion of tibia I gave the terminal segments of the leg an additional velocity late during the power stroke. The new velocity per unit length of leg segment was now determined graphically as the vectorial sum of the two velocities (Fig. 12), where the

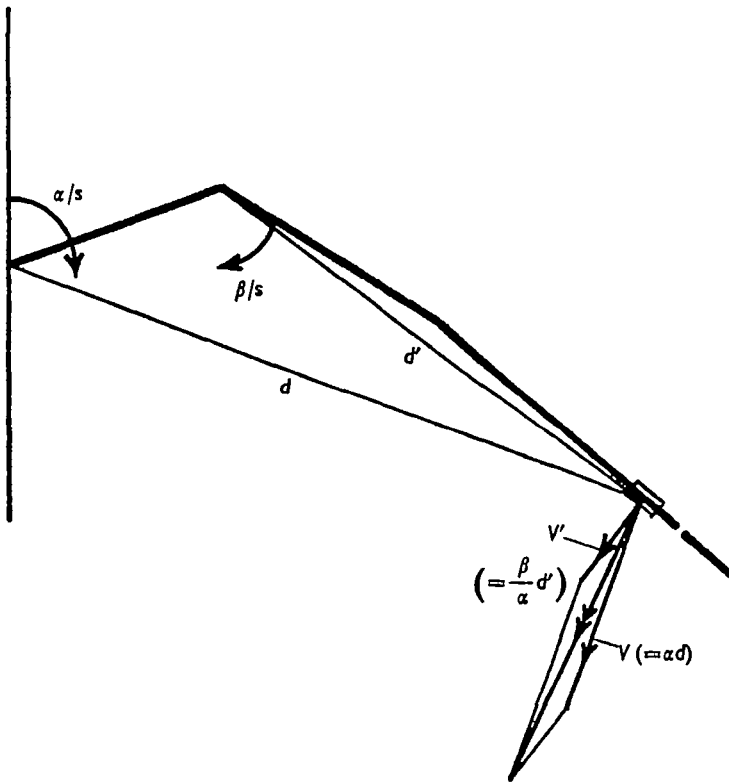

Fig. 12. Diagram illustrating the forces generated by the distal segments of the leg following flexion of the femoro-tibial joint during the power stroke. For details see text.

component of velocity attributable to the angular movement of the femur is $V = d\alpha$ radians/s, and the velocity resulting from the flexion of tibia I is $V' = d'(\beta/\alpha)$ radians/s. The velocity (and hence drag) acting perpendicularly to each segment of the leg was now derived from the vector as in equation (1), and resolved into its vertical and horizontal components.

I am grateful to Dr Richard Murray for much helpful discussion, and for reading a draft of the manuscript.

REFERENCES

- ALEXANDER, R. M. (1968). *Animal Mechanics*. London: Sidgwick and Jackson.
- BOUVIER, E. L. (1923). Pycnogonides. *Faune Fr.* 7, 69 pages.
- COLE, L. J. (1901). Notes on the habits of Pycnogonids. *Biol. Bull. mar. biol. Lab., Woods Hole* 2, 195-207.
- FAGE, L. (1932). Pêches planctoniques à la lumière effectuées à Banyuls sur Mer et à Concarneau. II. Pycnogonides. *Archs Zool. exp. gén.* 76, 105-248.
- GRAY, J. (1968). *Animal Locomotion*. London: Weidenfeld and Nicholson.
- HARTNOLL, R. G. (1960). Swimming in the spider crabs of the genus *Macropodia*. *Nature, Lond.* 185, 181.
- HELPER, H. & SCHLOTTKE, E. (1935). Pantopoda. *Bronn's Kl. Ordn. Tierreichs* 5 (4), 2. Buch.
- HUGHES, G. M. (1952). The coordination of insect movements. I. The walking movements of insects. *J. exp. Biol.* 29, 267-84.
- HUGHES, G. M. (1958). The coordination of insect movements. III. Swimming in *Dytiscus*, *Hydrophilus*, and a dragonfly nymph. *J. exp. Biol.* 35, 567-583.
- HUGHES, G. M. (1965). Locomotion: Terrestrial. In *Physiology of Insecta*, vol. 2 (ed. M. Rockstein), pp. 255-81. New York and London: Academic Press.
- KNIGHT-JONES, E. W. & MACFADYEN, A. (1959). The metachronism of limb and body movements in annelids and arthropods. *Proc. XVth Int. Congr. Zool.* pp. 969-71.
- LOCHHEAD, J. H. (1961). Locomotion. In *Physiology of Crustacea*, vol. 2 (ed. T. H. Waterman), pp. 313-64. New York and London: Academic Press.
- MANTON, S. M. (1950). The evolution of arthropodan locomotory appendages. I. The locomotion of *Peripatus*. *J. Linn. Soc. (Zool.)* 41, 529-70.
- MANTON, S. M. (1953). General introduction to the locomotory mechanisms of the Arthropoda. *J. Linn. Soc. (Zool.)* 42, 93-117.
- MANTON, S. M. (1958). Habits of life and evolution of body design in Arthropoda. *J. Linn. Soc. (Zool.)* 44, 58-72.
- MORGAN, E., NELSON-SMITH, A. & KNIGHT-JONES, E. W. (1964). Responses of *Nymphon gracile* (Pycnogonida) to pressure cycles of tidal frequency. *J. exp. Biol.* 41, 825-36.
- NACHTIGALL, W. (1960). Über kinematik, dynamik und energetik des Schwimmens einheimischer Dytisciden. *Z. vergl. Physiol.* 43, 48-119.
- NACHTIGALL, W. (1965). Locomotion. Swimming (hydrodynamics) of aquatic insects. In *Physiology of Insecta*, vol 2 (ed. M. Rockstein), pp. 255-81. New York and London: Academic Press.
- PRELL, H. (1910). Beiträge zur Kenntniss der Lebensweise einiger Pantopoden. *Bergens Mus. Årbog.* 10, 30 pages.
- PRINGLE, J. W. S. (1965). Locomotion: flight. In *Physiology of Insecta*, vol 2 (ed. M. Rockstein), pp. 283-329. New York and London: Academic Press.
- SCHAFER, W. (1954). Form und Funktion der Brachuanmschere. *Abh. senckenb. naturforsch. Gesch.* 489, 1-66.
- WEIS-FOGH, T. & JENSEN, M. (1956). Biology and physics of locust flight. I. Basic principles in insect flight. A critical review. *Phil. Trans. R. Soc. B* 239, 51-458.
- WILSON, D. M. (1966). Insect walking. *A. Rev. Ent.* 11, 103-22.

