

# Regulatory interactions specifying Kolmer-Agduhr interneurons

Lixin Yang, Sepand Rastegar and Uwe Strähle\*

## SUMMARY

In the zebrafish spinal cord, two classes of neurons develop from the lateral floor plate: Kolmer-Agduhr (KA'') and V3 interneurons. We show here that the differentiation of the correct number of KA'' cells depends on the activity of the homeobox transcription factor Nkx2.9. This factor acts in concert with Nkx2.2a and Nkx2.2b. These factors are also required for the expression of the zinc-finger transcription factor Gata2 in the lateral floor plate. In turn, Gata2 is necessary for expression of the basic helix-loop-helix transcription factor Tal2 that acts upstream of the GABA-synthesizing enzyme glutamic acid decarboxylase 67 gene (*gad67*) in KA'' cells. Expression of the transcription factor Sim1, which marks the V3 interneurons in the lateral floor plate, depends also on the three Nkx2 factors. *sim1* expression does not require, however, *gata2* and *tal2*. KA'' cells of the lateral floor plate and the KA' cells located more dorsally in the spinal cord share expression of transcription factors. The functional connections between the different regulatory genes, however, differ in the two GABAergic cell types: although *gata2* and *tal2* are expressed in KA' cells, they are dispensable for *gad67* expression in these cells. Instead, *olig2* and *gata3* are required for the differentiation of *gad67*-expressing KA' cells. This suggests that the layout of regulatory networks is crucially dependent on the lineage that differs between KA' and KA'' cells.

**KEY WORDS:** Kolmer-Agduhr interneuron, V3 interneuron, Zebrafish

## INTRODUCTION

Motoneurons and different interneuronal subtypes are specified in the ventral spinal cord in response to different concentrations of the morphogen sonic hedgehog (Shh). Close to the source of Shh (notochord, floor plate) V3 interneurons form, while, at a further distance, motoneurons and V2, V1 and V0 interneurons differentiate. The decreasing concentrations of Shh at a distance from the sources are interpreted by transcription factors, the expression of which is either repressed (class 1 transcription factors) or induced (class 2 transcription factors) by Shh (Briscoe and Ericson, 2001; Ingham and McMahon, 2001; Jessell, 2000).

The cells adjacent to the medial floor plate express the homeobox transcription factor genes *nkx2.2* and *nkx2.9*, which are induced by Shh (Cheesman et al., 2004; Guner and Karlstrom, 2007; Schäfer et al., 2005; Schäfer et al., 2007; Xu et al., 2006). In this region of the zebrafish spinal cord (the lateral floor plate), *nkx2.9* and two related *nkx2.2* genes, *nkx2.2a* and *nkx2.2b*, are expressed (Barth and Wilson, 1995; Schäfer et al., 2005; Schäfer et al., 2007; Strähle et al., 2004; Xu et al., 2006). Knockout of *Nkx2.2* in the mouse abolishes the formation of V3 interneurons (Briscoe et al., 1999), whereas inactivation of the related transcription factor *Nkx2.9* does not result in a phenotype in the mouse spinal cord (Pabst et al., 2003).

The zebrafish lateral floor plate is the origin of two distinct neuronal types: V3 interneurons and GABAergic Kolmer-Agduhr (KA'') cells (Fig. 1A,B) (Bernhardt et al., 1992; Schäfer et al., 2007). The KA'' cells of the lateral floor plate and the more dorsally located KA' cells form a special class of neurons that stay in contact with the ventricular lumen (Martin et al., 1998) (see also

Fig. 1A,B). Whereas the ventral KA'' cells develop from the lateral floor plate, the more dorsal KA' cells are derived from *olig2*-expressing motoneuron precursors (Park et al., 2004). At least some of the KA' cells are part of the neuronal network that controls spontaneous swimming movement (Wyart et al., 2009).

Although all these cell types depend on Shh signaling (Pinheiro et al., 2004; Schäfer et al., 2007), it is less clear how the Shh signals are interpreted to trigger the differentiation of KA interneurons. The zinc-finger transcription factors Gli1 (detour) and Gli2 (you-too) are the immediate mediators of the Shh signal in the spinal cord (Karlstrom et al., 1999; Karlstrom et al., 2003). The primary targets of the Gli factors appear to be *nkx2.2a*, *nkx2.2b* and *nkx2.9* (Cheesman et al., 2004; Guner and Karlstrom, 2007; Xu et al., 2006). As in mammals, zebrafish V3 interneurons express the leucine zipper/PAS domain transcription factor Sim1. In addition, a number of other transcription factors, such as the C4 zinc-finger transcription factors Gata2 and Gata3 and the basic helix-loop-helix transcription factor Tal2, are expressed in the lateral floor plate, but also in other cells at more dorsal aspects of the spinal cord (Batista et al., 2008; Pinheiro et al., 2004; Schäfer et al., 2007). The precise functional relationships of these factors with respect to the different neuronal subtypes are not understood. Morpholino knockdown of *nkx2.2a* and *nkx2.2b* does not abolish *tal2* expression in the zebrafish spinal cord (Schäfer et al., 2007). In the lateral floor plate, cells that co-express either *tal2* and *nkx2.2b* or *foxa2* and *nkx2.2b* can be distinguished (Schäfer et al., 2007). Although not affecting the *tal2*-positive cells, double knockdown of *nkx2.2a* and *nkx2.2b* abolishes the *foxa2/nkx2.2b* co-expressing cells. These latter cells seem to differ also in their dependence on hedgehog (Hh) signaling from *tal2*-positive cells. Moderate reduction of Shh signaling abolishes the *foxa2*-expressing cells, whereas complete removal of Shh signaling is necessary to prevent the differentiation of *tal2*-positive cells. The *foxa2/nkx2.2b* co-expressing and *tal2/nkx2.2b* co-expressing cells were suggested to represent proliferating and post-mitotic cells, respectively (Schäfer et al., 2007).

Institute of Toxicology and Genetics, Karlsruhe Institute of Technology (KIT), Postfach 3640, 76021 Karlsruhe, Germany.

\*Author for correspondence (uwe.straehle@kit.edu)

We investigated here the functional relationships of transcription factors expressed in the lateral floor plate (V3 interneurons, KA'') and KA' cells. Our data show that *nkx2.9* cooperates with *nkx2.2a* and *nkx2.2b* in the specification of V3 and KA'' cells. We provide evidence for distinct hierarchies of regulatory genes that are involved in the terminal differentiation of the different neuronal cell types. The transcription factor genes *tal2*, *gata2* and *gata3* are expressed in both KA' and KA'' cells, even though they are relevant for the differentiation of GABAergic character in only one of these cell types. Thus, the regulatory relationships differ in the two cell types, suggesting that the regulatory architecture might be dependent on the lineage of the cells and not just on the expression of particular transcription factors.

## MATERIALS AND METHODS

### Fish stocks

The wild-type zebrafish were derived from an intercross between the AB line and the wtOX line. Fish were bred and embryos staged as described (Kimmel et al., 1995; Westerfield, 1993).

### In situ hybridization, immunohistochemistry and sectioning

We carried out in situ hybridization as described (Oxtoby and Jowett, 1993), following, in the case of double stainings, the instructions of the suppliers of the reagents (Roche, PerkinElmer). For details of probes, see Table S1 in the supplementary material.

Counts of expressing cells were derived from the entire trunk and tail on both sides of the spinal cord. In colocalization studies, cells were counted on both sides over a distance of five somites in the spinal cord above the yolk extension.

### Morpholino knockdown

The morpholinos (Table 1) were resuspended in 0.1% Phenol Red and injected at 0.5 mM (single and double injection) or 0.25 mM (triple injection). As the penetrance of the effects on GABA immunoreactivity and *gad67* expression reached almost 100%, we believe that the degree of knockdown is sufficient. RT-PCR showed that the *gata2* splice morpholino efficiently blocks splicing of *gata2* mRNA at 48 hours post-fertilization (hpf).

## RESULTS

### *nkx2.2a*, *nkx2.2b* and *nkx2.9* have overlapping and complementary expression patterns in the ventral neural tube

The ventral spinal cord of the zebrafish embryo is composed of a number of distinct neurons. In the lateral floor plate, GABAergic KA'' cells, V3 interneurons and progenitor cells (P<sub>LF</sub>) are intermingled (Bernhardt et al., 1992; Lewis and Eisen, 2003; Schäfer et al., 2007) (Fig. 1A,B). At a slightly more dorsal position, motoneurons and progenitor cells (P<sub>MN</sub>) are found (Fig. 1A,B). The latter give rise to the GABAergic KA' cells and the ventral longitudinal descending interneurons (VeLD) (Bernhardt et al., 1992; Lewis and Eisen, 2003) (Fig. 1A,B).

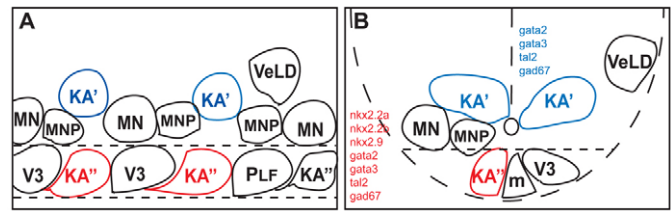

**Fig. 1. Outline of neuronal subtypes in the spinal cord of the zebrafish embryo.** Schemes of a lateral view (A) and cross-section (B) through the spinal cord of a zebrafish embryo. Kolmer-Agduhr (KA) interneurons are GABAergic neurons that contact the ventricular lumen. KA'' cells (red) differentiate in the lateral floor plate, whereas KA' cells (blue) are derivatives of the *olig2*-expressing motoneuron (MN) domain (Park et al., 2004). The cell type specificity of marker genes is indicated by color (blue, KA' cells; red, KA'' cells). The lateral floor plate contains, in addition to KA'' cells, V3 interneurons. The curving dashed line (B) outlines the neural tube and the horizontal dashed lines (A,B) highlight the dorsal boundary of the lateral floor plate. P<sub>LF</sub>, progenitor of lateral floor plate; MNP, motoneuron progenitor.

The homeobox genes *nkx2.2a*, *nkx2.2b* and *nkx2.9* share high sequence similarity and are expressed in the ventral neural tube in overlapping patterns (Barth and Wilson, 1995; Schäfer et al., 2005; Schäfer et al., 2007; Xu et al., 2006). Duplicated genes in the zebrafish genome have frequently diversified in expression, adopting specialized functions in addition to sharing redundant roles (Hadzhiev et al., 2007; Yan et al., 2005). We first compared the pattern of expression by analyzing stage-matched embryos hybridized to probes complementary to the three Nkx2 mRNAs.

In the brain of the 24-hour-old embryo, *nkx2.2a* was expressed in the hypothalamus, the regions flanking the zona limitans intrathalamica (prethalamus, thalamus) and the tegmentum of the midbrain (Fig. 2A). By contrast, *nkx2.2b* and *nkx2.9* showed a gap in the diencephalon, being expressed more in thalamic and prethalamic areas, respectively (Fig. 2D,G). All three genes were transcribed in the lateral floor plate of the hindbrain and spinal cord (Fig. 2B,C,E,F,H,I; data not shown). Whereas *nkx2.2b* was expressed in a continuous band in the lateral floor plate (Fig. 2E), *nkx2.9* transcripts were detectable at high levels in individual cells or in clusters of two to three cells separated by cells with no or very low expression (Fig. 2H). Similarly, *nkx2.2a* was expressed at different levels in the cells of the lateral floor plate, even though gaps expressed the gene at low, but always detectable, levels (Fig. 2B, arrowhead). Thus, the three genes have overlapping, but not identical, patterns of expression. The medial floor plate did not express any of the three genes (Fig. 2C,F,I), consistent with previous findings (Barth and Wilson, 1995; Guner and Karlstrom, 2007; Schäfer et al., 2005; Xu et al., 2006).

**Table 1. Sequence of morpholinos**

Gene	Morpholino (5'-3')	Control morpholino (5'-3')*	Region targeted	Concentration	Reference
<i>nkx2.2a</i>	CCGTCTTTGTGTTGGTCAACGACAT	CCcTCTTTcTGTTGcTCAAgGAgAT	ATG	0.5 mM	Kucenas et al., 2008
<i>nkx2.2b</i>	ATTCTTTAGGGACATTTCCAAACC	ATTgTTTAcGGAgATTTTaCAAAGc	ATG	10 ng/nl	Schäfer et al., 2007
<i>nkx2.9</i>	AACTGAACTGTTTGAAATAGCCAT	AAgTGAAgTTcTTcAAATAGCgAT	ATG	–	This paper
<i>olig2</i>	CACTCGGCTCGTGTCAGAGTCCATG	CAgTcCgCTCGTcTCAGAcTcGATG	ATG	1-2 ng/embryo	Zannino and Appel, 2009
<i>gata2</i>	CATCTACTACCAGTCTGCGCTTTG	CATcCtACTcActAGTcTaCGCTgTG	3rd exon/ intron boundary	0.2 mM	Galloway et al., 2005
<i>gata3</i>	CCGGACTTACTTCCATCGTTTATT	CCcGACTTAgTTCgATcTTTtTTT	ATG	–	This paper
<i>tal2</i>	GTTAGTGAACACCTTCTGTGCATG	GTaAGTcAACACCTTgCTcGTcATG	ATG	–	This paper

Morpholinos were tested over a range of concentrations. Control morpholinos were injected at the same concentration as the knockdown morpholino. Concentrations were 0.5 mM in single and double injections and 0.25 mM in triple injections.

\*Mismatches in control morpholinos are indicated by lowercase letters.

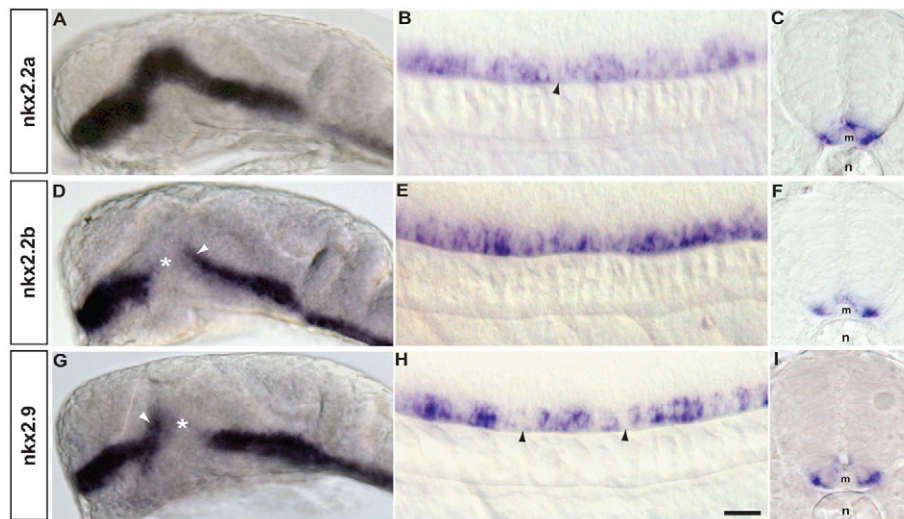
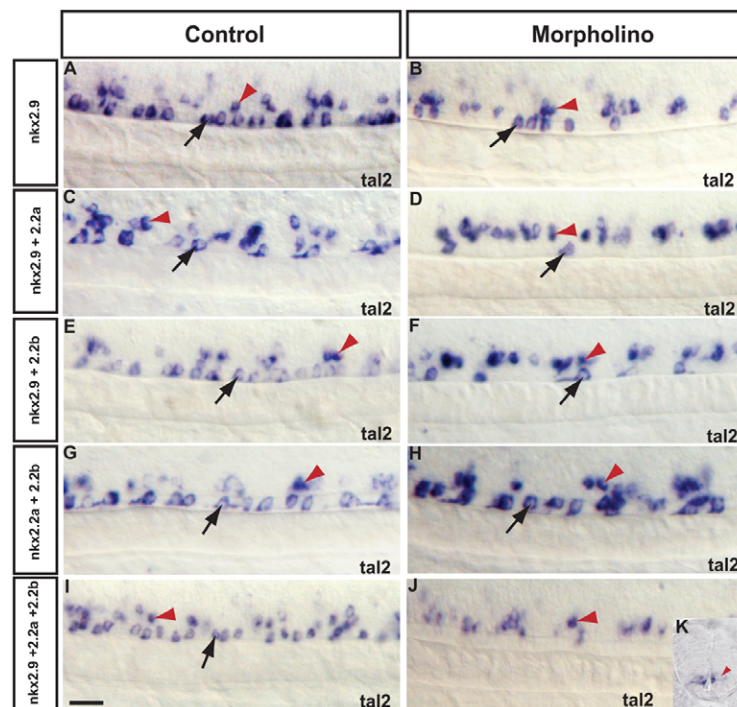

**Fig. 2. *nkx2.2a*, *nkx2.2b* and *nkx2.9* are expressed in overlapping domains.** (A-I) Head (A,D,G) and trunk (B,E,H lateral view; C,F,I transverse section) of a 24 hpf zebrafish embryo hybridized to *nkx2.2a* (A-C), *nkx2.2b* (D-F) and *nkx2.9* (G-I) antisense probes. Whereas expression of *nkx2.2a* (A) along the ventral brain is continuous, the expression domains of *nkx2.2b* and *nkx2.9* show a gap (D,G, asterisk) in the prethalamic and thalamic areas adjacent to the zona limitans intrathalamica. All three genes are expressed in the lateral floor plate of the trunk. In the spinal cord (B,E,H), the expression of *nkx2.2a* and *nkx2.9* is discontinuous, with gaps of non-expressing cells (B,H, black arrowheads), whereas all cells of the lateral floor plate appear to express *nkx2.2b* (E). All three genes are restricted to the lateral floor plate (C,F,I). Orientation of whole-mount embryos (A,B,D,E,G,H): anterior left, dorsal up. Lateral views of the head (A,D,G) and the spinal cord are at the level of the hindgut extension. Transverse sections (C,F,I) are at the level of the hindgut extension, dorsal up. m, medial floor plate; n, notochord. Scale bar: 100  $\mu$ m in A,D,G; 25  $\mu$ m in B,C,E,F,H,I.

### ***nkx2.2a*, *nkx2.2b* and *nkx2.9* are required for *tal2* expression in the lateral floor plate**

In mammals, *Nkx2.2* plays a crucial role in the development of V3 interneurons (Briscoe et al., 1999). However, previous knockdown experiments in zebrafish (Schäfer et al., 2007), in which the translation of *nkx2.2a* and *nkx2.2b* was blocked, did not affect expression of the bHLH transcription factor *tal2*, a neuronal marker (Pinheiro et al., 2004; Schäfer et al., 2007).

We tested whether *nkx2.9* is required for the expression of *tal2* in the lateral floor plate by injecting an antisense morpholino (*Mo-nkx2.9*) directed to the translation start site (Table 1). Knockdown of *nkx2.9* translation resulted in ~50% reduction of *tal2*-positive cells in the lateral floor plate (Fig. 3A,B; Fig. 4). More dorsally located cells expressing *tal2* were not affected, showing that this effect is specific for the lateral floor plate (Fig. 3A,B). When *Mo-nkx2.9* was co-injected together with a morpholino directed against



**Fig. 3. *tal2* expression in the lateral floor plate depends on *nkx2.2a*, *nkx2.2b* and *nkx2.9*.** (A,B) Control (A) and *Mo-nkx2.9*-injected (B) zebrafish embryo. Knockdown of *nkx2.9* leads to a reduction of *tal2*-positive cells in the lateral floor plate (arrow) but dorsal *tal2*-positive cells are unaffected (arrowhead). (C,D) Control (C) and *Mo-nkx2.9/Mo-nkx2.2a*-injected (D) embryos. There is a reduction of *tal2*-positive cells in the lateral floor plate, whereas *tal2*-expressing cells (arrowhead) further dorsal in the spinal cord are unaffected in the double-knockdown embryos. (E,F) Control (E) and *Mo-nkx2.9/Mo-nkx2.2b*-injected (F) embryos. There is a reduction of *tal2*-positive cells in the lateral floor plate (arrow) in the double-knockdown embryos. (G,H) Control (G) and *Mo-nkx2.2a/Mo-nkx2.2b*-injected (H) embryos. Double knockdown of *nkx2.2a* and *nkx2.2b* caused little reduction of *tal2*-positive cells (arrow) in the lateral floor plate. (I,J) Control (I) and triple-knockdown (J) embryos. Knockdown of all three *Nkx2* genes abolished *tal2*-positive cells in the lateral floor plate (arrow). *tal2*-expressing cells (arrowhead) further dorsal in the spinal cord were unaffected in these knockdown embryos. (K) Cross-section through the trunk at hindgut extension of a triple-knockdown embryo. *tal2*-expressing cells in the lateral floor plate (arrow) are missing, whereas more dorsally located *tal2*-positive cells are present (arrowhead). Note that controls represent injections of mismatch morpholinos or combinations thereof (Table 1). Representative lateral views of the spinal cord over the hindgut extension are shown. Embryos (24 hpf) are shown with anterior left, dorsal up. Scale bar: 25  $\mu$ m.



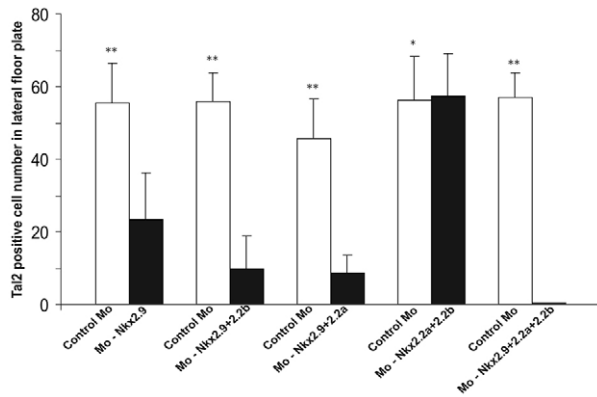
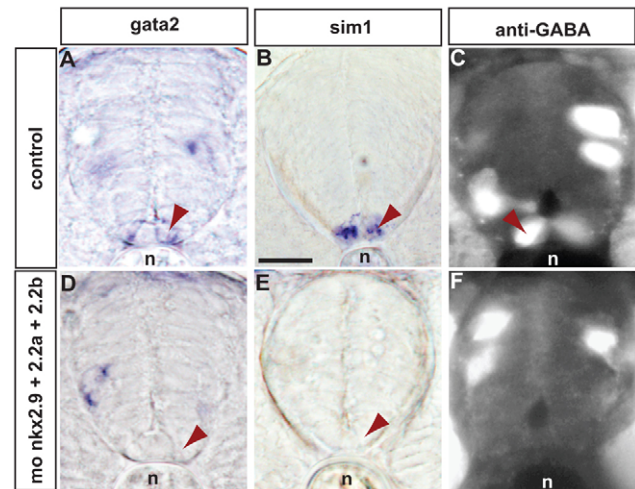

**Fig. 4. Quantification of *tal2*-positive cells in the lateral floor plate of *Nkx2* knockdown zebrafish embryos.** Embryos injected with combinations of morpholinos *Mo-nkx2.2a*, *Mo-nkx2.2b* and *Mo-nkx2.9* or the corresponding mismatch controls (Table 1) were stained with the *tal2* antisense probe (see Fig. 3). The *tal2*-positive cells in the lateral floor plate of the entire spinal cord were counted on both sides of the embryo. Each column represents the average of the counts of at least 15 embryos at 24 hpf. Error bars indicate s.d. \*\*,  $P < 0.0001$ ; \*,  $P > 0.05$ ; Student's *t*-test.

either *nkx2.2a* (*Mo-nkx2.2a*) or *nkx2.2b* (*Mo-nkx2.2b*) mRNA, a further reduction of lateral floor plate, but not dorsal, *tal2*-expressing cells was noted (Fig. 3C-F; Fig. 4). This indicates that the two closely related *nkx2.2* genes also play a role in the specification of *tal2*-expressing cells. This result appears to contradict a previous report, in which morpholinos directed against *nkx2.2a* and *nkx2.2b* mRNA did not result in a reduction of *tal2*-positive cells (Schäfer et al., 2007). We repeated these experiments (Fig. 3G,H; Fig. 4) and found that double knockdown of *nkx2.2a* and *nkx2.2b* indeed does not lead to loss of *tal2*-positive cells. When all three *Nkx2* genes were knocked down, *tal2*-expressing cells were completely lost in the lateral floor plate, whereas more dorsally located cells were unaffected (Fig. 3I,J; Fig. 4). This shows that *nkx2.2a*, *nkx2.2b* and *nkx2.9* are required for *tal2* expression in the lateral floor plate. Moreover, these results indicate a partially redundant function of the three *Nkx2* genes: *nkx2.9* function appears to be more crucial, whereas the other two genes contribute to the development of *tal2*-positive interneurons; however, this function is only detectable when *nkx2.9* is knocked down.

The specificity of the knockdowns was controlled by injection of morpholinos carrying five mismatches (Table 1). Neither individual nor combined injection of these control morpholinos abolished the formation of *tal2*-positive cells (Fig. 3A,C,E,G,I; Fig. 4). The specificity of the effect is further underscored by the observation that the co-injection of *Mo-nkx2.2a* and *Mo-nkx2.2b* did not cause an effect and that the effect of *Mo-nkx2.9* only became fully penetrant when the other two morpholinos were co-injected.

We next examined whether the lateral floor plate cells would be transformed into more dorsal cells in triple-knockdown embryos. The expression of the homeo/paired box transcription factors *pax6.1* and *pax6.2* (also known as *pax6a* and *pax6b*, respectively – Zebrafish Information Network) is detectable immediately dorsal to the lateral floor plate (see Fig. S1G,I in the supplementary material). The expression domains of *pax6.1* and *pax6.2* were not expanded ventrally into the lateral floor plate in triple-knockdown embryos (see Fig. S1G-J in the supplementary material). By



**Fig. 5. *gata2*-expressing, *sim1*-expressing and GABAergic cells are missing in the lateral floor plate of triple-knockdown zebrafish embryos.** (A-F) Transverse sections through control morpholino-injected (A-C) and triple-injected (*Mo-nkx2.9*, *Mo-nkx2.2a*, *Mo-nkx2.2b*) (D-F) embryos were hybridized to *gata2* (A,D) or *sim1* (B,E) antisense probe or anti-GABA antibody (C,F). Cells in the lateral floor plate (arrowhead) that express *gata2* and *sim1* or that are GABAergic are abolished by triple knockdown of *nkx2.2a*, *nkx2.2b* and *nkx2.9* (D-F), whereas cells expressing the same markers more dorsally appear unaffected. Embryos were 24 (A,C,D,F) or 48 (B,E) hpf. All transverse sections were cut at the level of the yolk extension. n, notochord. Scale bar: 25  $\mu$ m.

contrast, when triple-knockdown embryos were stained with antisense probe directed against the bHLH factor *olig2* mRNA, we noted an expansion of the *olig2* domain of expression into the lateral floor plate (see Fig. S1K,L in the supplementary material). Thus, the *Nkx2* genes appear to be required to suppress the expression of the motoneuron and oligodendrocyte marker *olig2* in the lateral floor plate.

### Triple knockdown of the *Nkx2* genes impairs the differentiation of GABAergic neurons

We next assessed whether knockdown of the three *Nkx2* genes abolishes the expression of other neuronal marker genes expressed in the lateral floor plate. The mRNA of the zinc-finger transcription factor *Gata2* can be detected in KA'' cells in the lateral floor plate and in V2b/VeLD and KA' cells in more dorsal regions (Batista et al., 2008; Detrich et al., 1995) (see Fig. 6). Triple-knockdown embryos (24 hpf) did not express *gata2* in the lateral floor plate (control,  $46 \pm 2$  *gata2*-positive cells,  $n=10$  embryos; triple-knockdown embryos,  $1 \pm 1$  *gata2*-positive cell,  $n=10$  embryos). More dorsally located cells expressing the *gata2* gene were unaffected by the knockdown of the *Nkx2* genes (Fig. 5D; for lateral views see Fig. S1A,B in the supplementary material). Injection of a cocktail of the three mismatch morpholinos did not affect the pattern of *gata2* expression in the spinal cord (Fig. 5A).

The leucine zipper/PAS transcription factor gene *single-minded homolog 1* (*sim1*) is expressed in scattered cells in the lateral floor plate of zebrafish embryos (Schäfer et al., 2007) and is a marker for V3 interneurons in the murine spinal cord (Fan et al., 1996). In contrast to that of *tal2* and *gata2*, *sim1* expression is not detectable until the second day of development, and so embryos were analyzed at 48 hpf. *sim1* mRNA was not detectable (Fig. 5B,E; for a lateral

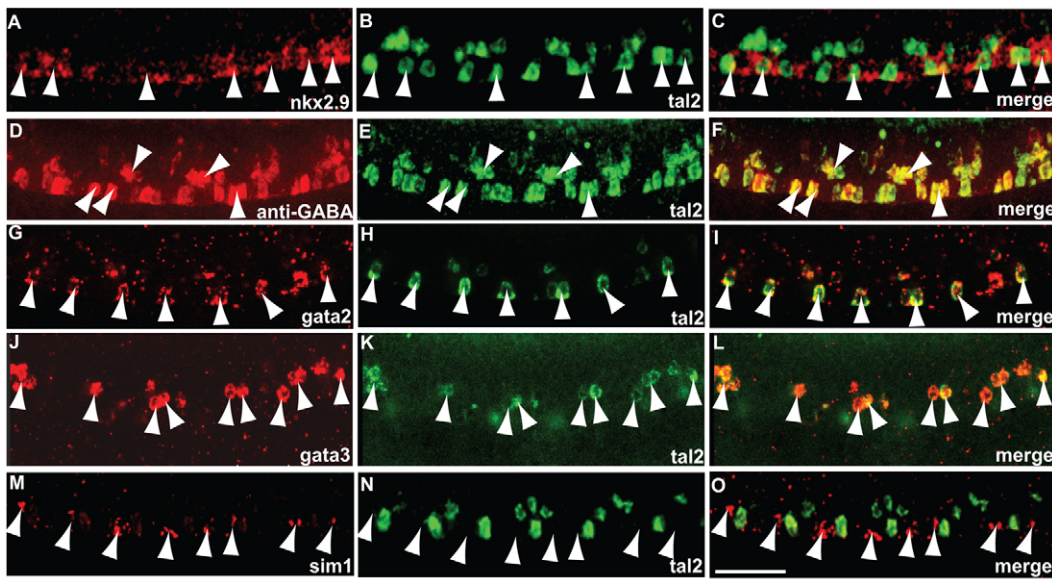

**Fig. 6. Mapping co-expression of marker genes and GABA in the zebrafish lateral floor plate.** (A-C) *nkx2.9* (A) and *tal2* (B) mRNA expression and a merged view (C). *nkx2.9*-positive cells (arrowheads) co-express *tal2*. (D-F) GABA immunohistochemistry (D), *tal2* in situ hybridization (E) and a merged view (F). *tal2*-expressing cells (arrowheads) are GABAergic. (G-I) *gata2* (G) and *tal2* (H) mRNA expression and a merged view (I). *gata2* and *tal2* mRNAs (arrowheads) are co-expressed in the lateral floor plate. More dorsally in the spinal cord, not all *gata2*-positive cells are *tal2*-positive. (J-L) *gata3* (J) and *tal2* (K) mRNA expression and merge (L). *gata3* mRNA-expressing cells co-express *tal2* mRNA in the lateral floor plate. However, more dorsally, only a proportion of *gata3*-positive cells also expresses *tal2* mRNA. The *tal2*-negative, *gata2*- and *gata3*-positive cells are probably V2b/VeLD interneurons (Batista et al., 2008). (M-O) *sim1* (M) and *tal2* (N) mRNA expression and merge (O). *sim1*-expressing interneurons and *tal2*-expressing cells in the lateral floor plate are distinct in most cases. Only in 25% of cells did we find co-expression of the two markers. (A-F) Projections of several sections. (G-O) Single confocal planes. Embryos were 24 (A-L) or 36 (M-O) hpf. Dorsal up, anterior left. Scale bar: 50  $\mu$ m.

view see Fig. S1C,D in the supplementary material) in triple-knockdown embryos, and injection of the mismatch morpholinos did not affect the pattern of expression (control,  $82 \pm 10$  *sim1*-positive cells,  $n=16$  embryos; triple-knockdown embryos,  $1 \pm 1$  *sim1*-positive cell,  $n=12$  embryos). *sim1* expression was not affected in *nkx2.2a/nkx2.2b* double-knockdown or *nkx2.9* single-knockdown embryos (see Fig. S2A,B in the supplementary material; data not shown). This suggests that the three Nkx2 genes are required for the specification of *sim1*-expressing cells. In the mouse spinal cord, V3 interneurons are excitatory and express the vesicular glutamate transporter *Vglut2.1* (*Slc17a6* – Mouse Genome Informatics) (Zhang et al., 2008). To assess whether *sim1* cells correspond to zebrafish V3 interneurons, we carried out co-expression studies at 36 hpf. From 88 *sim1*-expressing cells ( $n=6$  embryos), 72 cells expressed *vglut2.1* at 36 hpf (see Fig. S3A-C in the supplementary material). Thus *sim1*-expressing cells appear to correspond mostly to V3 interneurons. Also, the expression of *vglut2.1* in the lateral floor plate was abolished in Nkx2 triple-knockdown embryos (see Fig. S2E,F in the supplementary material).

In addition to *sim1*-expressing cells, the lateral floor plate is also the origin of KA'' interneurons, which are characterized by synthesis of the neurotransmitter GABA (Bernhardt et al., 1992; Martin et al., 1998). GABA immunoreactivity was depleted in the lateral floor plate in triple-knockdown embryos (triple-knockdown embryos,  $2 \pm 2$  GABA-positive cells,  $n=10$  embryos; Fig. 5C,F; see Fig. S1E,F in the supplementary material). Embryos injected with the mixture of control morpholinos showed a normal pattern of GABA-synthesizing cells (control,  $54 \pm 8$  GABA-positive cells,  $n=17$  embryos). Hence, Nkx2 genes are required for the differentiation of GABAergic KA'' neurons.

### ***nkx2.9*-positive cells express *tal2* and are GABAergic**

In contrast to *nkx2.2b*, expression of *nkx2.9* in the lateral floor plate is not continuous but is interrupted by cells that express *nkx2.9* at very low levels or not at all (Fig. 2H). Therefore, we examined whether *nkx2.9*-positive cells co-express *tal2* mRNA by double in situ hybridization with *nkx2.9* and *tal2* probes. In two-thirds of *nkx2.9*-expressing cells, we also detected expression of *tal2* mRNA (66%, 111 cells,  $n=7$  embryos; Fig. 6A-C).

We next assessed whether the *tal2*-expressing cells were GABAergic by staining embryos (24 hpf) hybridized to the *tal2* antisense probe with an anti-GABA antibody. Not only the ventral *tal2*-positive cells in the lateral floor plate, but also the more dorsally located *tal2*-positive cells synthesized GABA (100%, 101 cells,  $n=10$  embryos; Fig. 5D-F). Thus, *tal2*-expressing cells in the lateral floor plate are identical to the GABAergic KA'' cells. The more dorsally located *tal2*/GABA-positive cells correspond to KA' cells (Batista et al., 2008; Park et al., 2004). This was confirmed by transverse sectioning of *tal2*-stained embryos: more dorsally located *tal2*-positive cells were in contact with the ventricle, in agreement with their identity as KA' cells (data not shown).

Next, we mapped the expression of the zinc-finger transcription factor gene *gata2* relative to *tal2*-expressing cells. Almost all *gata2*-expressing cells in the lateral floor plate also expressed *tal2* mRNA (94%, 94 cells examined,  $n=5$  embryos), whereas only a fraction of *gata2*-expressing cells in more dorsal aspects of the spinal cord co-labeled with *tal2* mRNA (Fig. 6G-I). *gata2* expression was lower in the row 2 cells corresponding to KA' cells than in the cells of the lateral floor plate. As with *gata2*, mRNA of



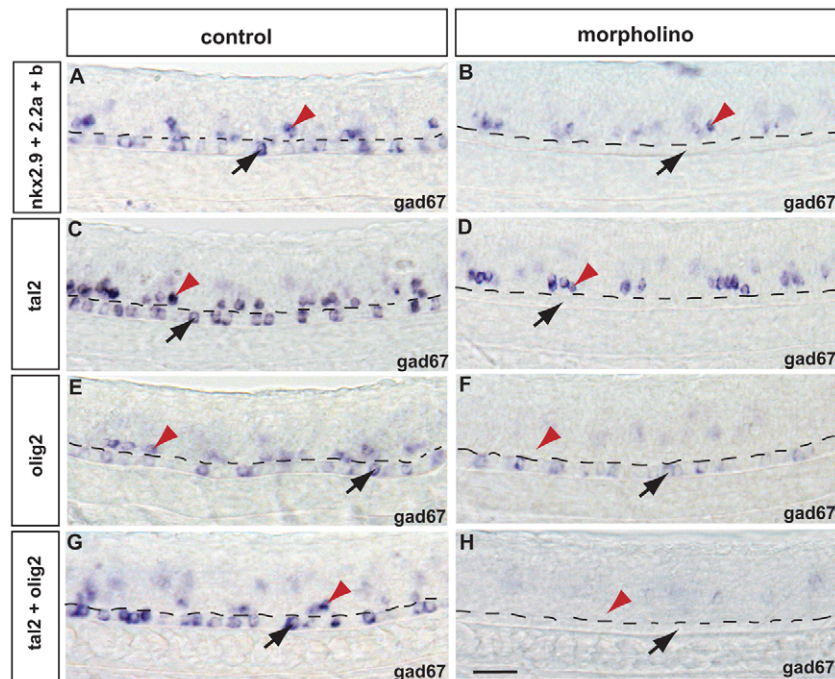

**Fig. 7. *gad67* expression in KA' and KA'' cells is differentially dependent on *tal2* and *olig2*.** (A,B) Zebrafish embryos injected with a mixture of mismatch morpholinos (A) or a cocktail of morpholinos directed against *nkx2.2a*, *nkx2.2b* and *nkx2.9* mRNA (B). The *nkx2* cocktail abolished *gad67* expression in KA'' cells (arrow) in the lateral floor plate (B). *gad67* expression in KA' and VeLD cells (arrowhead) was not affected by the knockdown of the Nkx2 genes. (C,D) Embryos injected with a mismatch morpholino (C) or with a morpholino directed against *tal2* mRNA (D). *gad67* expression in KA'' cells (arrow) was abolished in the *tal2* morphants, whereas *gad67* expression in KA' and VeLD cells (arrowhead) appeared to be normal. (E,F) Embryos injected with a mismatch morpholino (E) or a morpholino directed against *olig2* mRNA (F). The strong *gad67* expression in dorsally located cells (arrowhead) was abolished by knockdown of *olig2*. Expression in KA'' cells (arrow) and the low-level expression in what are presumably V2 interneurons was not affected by knockdown of *olig2* expression. (G,H) Embryos injected with either a mix of *tal2* and *olig2* mismatch control morpholino (G) or with morpholinos directed against *tal2* and *olig2* mRNA (H). Co-injection of the *tal2* and *olig2* morpholinos abolished *gad67* expression in both the KA' (arrowhead) and KA'' (arrow) interneurons. Expression of *gad67* in some dorsally located cells, which probably represent V2 interneurons expressing *gad67* at low levels, still persisted in the spinal cord of double-injected morphants. Embryos were 24 hpf. Anterior left, dorsal up. Scale bar: 25  $\mu$ m.

the related factor *gata3* was co-expressed in the *tal2*-expressing cells in the lateral floor plate (96%, 85 cells,  $n=5$  embryos) and also in a number of cells at a more dorsal location in the spinal cord (Fig. 6J-L). Since the *tal2*-positive cells also expressed GABA (Fig. 6D-F), this suggests that *gata3* and *tal2* are co-expressed in both the ventral KA'' cells and the more dorsal KA' cells.

We next examined the relationship between *sim1*-expressing V3 cells and *tal2* expression. Only a quarter of *sim1*-positive cells expressed *tal2* in double-labeled 36 hpf embryos (28 of 113 cells,  $n=8$  embryos; Fig. 6M-O). Thus, GABAergic KA'' and V3 interneurons only partly share marker expression in the 36 hpf embryo.

### The transcription factors Tal2 and Olig2 are required for *gad67* expression in KA'' and KA' cells, respectively

We next investigated the epistatic relationships between the different factors expressed in the GABAergic cells in the lateral floor plate. As a marker for these cells, we used the expression of the GABA-synthesizing enzyme *glutamic acid decarboxylase 67* gene (*gad67*; also known as *gad1* – Zebrafish Information Network). First, we verified that expression of *gad67* in the lateral floor plate is also dependent on the activity of Nkx2 genes. Triple knockdown of *nkx2.2a*, *nkx2.2b* and *nkx2.9*

abolished expression of *gad67* in the lateral floor plate completely ( $n=16$  embryos; Fig. 7A,B), confirming the immunohistochemical results (Fig. 5C,F).

Since *tal2* is expressed in cells that produce GABA, we tested whether *tal2* is required for expression of *gad67*. *tal2* knockdown embryos lacked expression of *gad67* in the lateral floor plate, whereas more dorsally located *gad67*-expressing cells were unaffected by the knockdown of *tal2* ( $n=18$  embryos; Fig. 7C,D). Control embryos that were injected with a five-mismatch morpholino showed normal *gad67* expression. This suggests that *tal2* acts upstream of *gad67* in KA'' cells of the lateral floor plate but seems to be dispensable for *gad67* expression in KA' cells.

The bHLH factor Olig2 controls motoneuron and oligodendrocyte development (Park et al., 2004). To assess whether *olig2* is required for the development of *gad67*-positive cells, *olig2* translation was knocked down by injection of a previously employed morpholino (Zannino and Appel, 2009). Knockdown of *olig2* abolished *gad67* expression in KA' cells, but *gad67* expression was still present in the lateral floor plate ( $n=15$  embryos; Fig. 7E,F). We also tested the effect of *olig2* knockdown on *tal2* expression. As with *gad67*, expression of *tal2* was abolished in dorsally located KA' cells but not in the KA'' cells of the lateral floor plate (data not shown). This suggests that *tal2* expression and/or KA' cell differentiation are under the control of

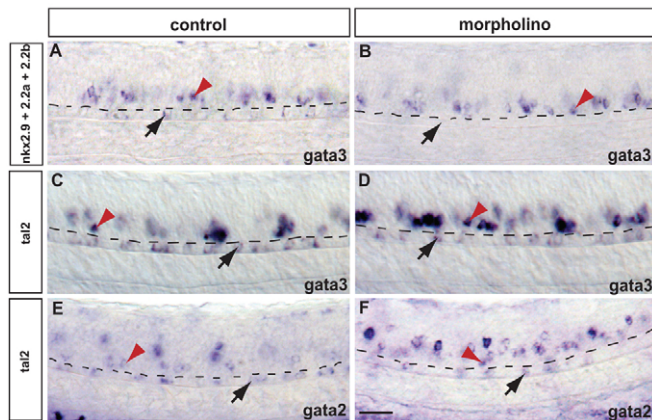

**Fig. 8. *gata2* and *gata3* expression in the lateral floor plate requires Nkx2 genes but not *tal2*.** (A,B) Zebrafish embryos injected with a mix of mismatch morpholinos (A) or morpholinos directed against *nkx2.2a*, *nkx2.2b* and *nkx2.9* mRNA (B). *gata3*-expressing cells are not detectable in the lateral floor plate (arrow) in triple morphants, whereas dorsally located *gata3*-expressing cells (arrowhead) are present. (C,D) Embryos injected with a mismatch control morpholino (C) or a morpholino directed against *tal2* mRNA (D). *tal2* knockdown does not affect *gata3* expression, indicating that *tal2* does not regulate *gata3*. (E,F) Embryos were injected with a mismatch morpholino (E) or a morpholino directed against *tal2* mRNA (F). *gata2* expression is not abolished by knockdown of *tal2* expression. Embryos were 24 hpf. Anterior left, dorsal up. Scale bar: 25  $\mu$ m.

*olig2*. *tal2* activity is, however, not required for the expression of *gad67* in KA' cells. Injection of the mismatch control morpholino did not affect *gad67* or *tal2* expression (Fig. 7E; data not shown). Interestingly, knockdown of *olig2* abolished *gata3* expression in KA' cells but did not affect the expression in KA'' cells nor presumably VeLD/V2b cells (see Fig. S2K,L in the supplementary

material). When the *tal2* and *olig2* morpholinos were injected together, *gad67* expression at the location of both KA' and KA'' cells was abolished ( $n=25$  embryos; Fig. 7G,H; see Fig. S2I,J in the supplementary material). Taken together, these data strongly suggest that *gad67* expression and/or the differentiation of KA'' and KA' cells are specified by distinct mechanisms.

### ***gata2* and *gata3* expression in the lateral floor plate require Nkx2 genes but not *tal2***

The triple knockdown of the Nkx2 genes suggested that they are required for *gata2* expression in the lateral floor plate. Since *gata3* is expressed in a pattern overlapping with that of *gata2* (Fig. 6G-L), we tested whether *gata3* is also dependent on the Nkx2 genes. Triple-knockdown embryos lacked *gata3* expression in the lateral floor plate, whereas expression in more dorsal aspects in KA' and VeLD/V2b cells was not affected ( $n=18$  embryos; Fig. 8A,B). Thus, *gata3* expression, like that of *gata2*, depends on the Nkx2 genes in lateral floor plate cells.

Since *tal2* expression overlaps with that of *gata2* and *gata3*, we tested whether *tal2* is required for their expression (Fig. 8C-F). Knockdown of *tal2* abolished neither *gata3* (Fig. 8C,D) nor *gata2* expression in the lateral floor plate (Fig. 8E,F), even though the same injection led to loss of *gad67* expression (Fig. 7C,D; data not shown). Thus, *tal2* could act downstream of *gata2* and *gata3* or in parallel pathways.

We also analyzed whether *sim1* expression depends on *tal2*. *sim1* expression was not affected in *tal2* morphants (data not shown), suggesting that *tal2* is not required for *sim1* expression, even though *tal2* expression is detectable in a fraction of *sim1*-positive cells at 36 hpf.

### ***gata2* controls the development of KA' cells, whereas *gata3* is required for KA' cells**

Since knockdown of *tal2* did not have an effect on *gata2* and *gata3* expression, we hypothesized that *gata2* and *gata3* act upstream of *tal2*. To test this, we injected morpholinos against

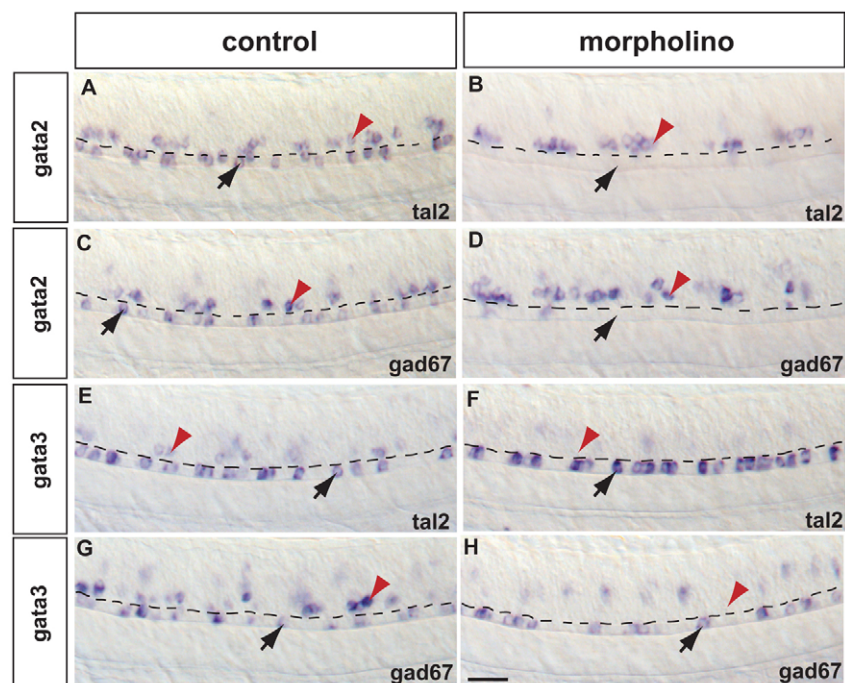

**Fig. 9. *gata2* and *gata3* differentially regulate *gad67* expression in KA' and KA'' interneurons.** (A-D) Zebrafish embryos injected with mismatch morpholino (A,C) or with morpholinos directed against *gata2* mRNA (B,D). *gata2* abolishes *tal2* expression (B) as well as *gad67* expression (D) in the lateral floor plate (arrow). Thus, correct differentiation of KA'' cells in the lateral floor plate requires *gata2* function. (E-H) Embryos injected with mismatch morpholino (E,G) or morpholinos directed against *gata3* mRNA (F,H). *tal2* (E,F) and *gad67* (G,H) expression in KA' cells is abolished by *gata3* knockdown (arrowhead), whereas expression in KA'' cells is unaffected (arrow). Embryos were 24 hpf. Anterior left, dorsal up. Scale bar: 25  $\mu$ m.



*gata2* and stained embryos with *tal2* or *gad67* probes. Knockdown of *gata2* abolished expression of *tal2* in the lateral floor plate, whereas *tal2* expression was unaffected in more dorsal positions corresponding to KA' and V2b/VeLD cells ( $n=20$  embryos; Fig. 9A,B; see Fig. S2G,H in the supplementary material). Knockdown of *gata2* abolished *gad67* expression in the lateral floor plate in the same manner as it abolished *tal2* expression ( $n=15$  embryos; Fig. 9C,D). Expression of *gad67* in KA' cells was unaffected, as was *tal2* expression, in the *gata2* morphants (Fig. 9C,D). These results are in line with the notion that *gata2* acts upstream of *tal2* and *gad67* in KA' cells. As *gad67* expression depends also on *tal2* function (Fig. 7C,D), this suggests that *gata2* acts directly or indirectly through *tal2* on *gad67* expression. Interestingly, *gata2* morphants also showed loss of *gata3* expression in the lateral floorplate, suggesting that *gata3* is directly or indirectly under the control of *gata2* in KA' cells (see Fig. S2M,N in the supplementary material).

Next, we analyzed the role of *gata3* in the control of *tal2* and *gad67* transcription. In *gata3* morphants, expression of *tal2* and *gad67* was abolished in KA' cells, but their expression in KA'' cells was unaffected. Hence, *gata2* and *gata3* morphants present complementary patterns of activity: *gata2* is required for the expression of *gad67* and *tal2* in, and/or for the differentiation of, KA'' cells, whereas *gata3* is necessary for the control of *gad67* and *tal2* expression in, and/or for the differentiation of, KA' cells. Thus, the related genes *gata2* and *gata3* do not act redundantly but have specific functions in the two cell types. *tal2/gad67*-expressing V2b/VeLD cells, which are distinguished from KA' cells by their pial location and characteristic cell shape, are not affected by the knockdown of *gata3* (data not shown).

Since V3 interneurons depend on Nkx2 gene function (Fig. 5B,E), we tested whether *gata2* or *gata3* could be employed in the specification of these cells. However, 48-hour-old *gata2* and *gata3* morphants formed *sim1*- and *vglut2.1*-expressing cells normally (see Fig. S2C,D in the supplementary material; data not shown), suggesting that *gata2* and *gata3* are not required. Thus, the regulatory mechanisms controlling V3 interneuron differentiation downstream of Nkx2 genes differ from those of KA'' cells.

## DISCUSSION

### The role of *nkx2.2a*, *nkx2.2b* and *nkx2.9* in interneuron differentiation

Differentiation of V3 and KA'' interneurons in the lateral floor plate of the zebrafish spinal cord relies on *nkx2.9* and on the two related genes *nkx2.2a* and *nkx2.2b*. In the mouse, *Nkx2.2* plays a crucial role in the specification of V3 interneurons (Briscoe et al., 1999). However, simultaneous knockdown of *nkx2.2a* and *nkx2.2b* in the zebrafish does not abolish the differentiation of V3 interneurons nor of the KA'' cells marked by *tal2* and *gad67* expression (Schäfer et al., 2007) (this study). Only when *nkx2.2a* and *nkx2.2b* were knocked down together with *nkx2.9* did we observe a complete loss of V3 and KA'' interneurons. By contrast, knockout of *Nkx2.9* in the mouse does not lead to loss of the P3/V3 compartment of the spinal cord (Pabst et al., 2003): *Nkx2.9*<sup>-/-</sup> mice have a rather mild phenotype, with defects in the spinal accessory nerve and with lower penetrance in the vagal and glossopharyngeal nerves (Pabst et al., 2003). Whereas *Nkx2.2* is essential for the differentiation of the P3/V3 compartment in the spinal cord of the mouse, *nkx2.9* plays a crucial role in this differentiation process in the zebrafish, suggesting that the relative importance of *nkx2.2* and *nkx2.9* has changed during evolution.

This might reflect an independent drift of function in the two vertebrate lineages upon duplication of a common ancestral gene (Hadzhiev et al., 2007; Yan et al., 2005).

Although there are neurons contacting the cerebrospinal fluid in the mammalian CNS (Stoeckel et al., 2003), it is not clear whether the mammalian spinal cord has KA cells. *Tal2* is not expressed in the mouse spinal cord (Pinheiro et al., 2004). KA cells might thus be associated with the specification of the neuronal network characteristic of anamniotes that underlies the swimming movement of their free-living embryos and larvae (Wyart et al., 2009). Interestingly, V3 neurons in the mammalian spinal cord are involved in the control of the regularity and robustness of locomotor rhythms during walking (Zhang et al., 2008).

The *nkx2.2a*, *nkx2.2b* and *nkx2.9* genes act in a partially non-redundant manner. Knockdown of *nkx2.9* resulted in a 50% reduction in *tal2*-positive cells, suggesting that *nkx2.2a* and *nkx2.2b* cannot compensate totally for the loss of *nkx2.9* function. Although *sim1*- and *tal2*-expressing cells in the lateral floor plate were unaffected, Schäfer et al. noted that *nkx2.2b/foxa2*-positive cells do not form in *nkx2.2a/nkx2.2b* double morphants (Schäfer et al., 2007). This also suggests specialized functions of the three genes in the lateral floor plate. In this context, it might be of note that not all lateral floor plate cells express *nkx2.9* and *nkx2.2a* with equal intensity. Expression of *nkx2.2b*, however, appears to be present in all cells at 24 hpf in line with a specific function that is different from those of the other two Nkx2 genes. Schäfer et al. suggested that *nkx2.2b/foxa2* co-expressing cells continue to proliferate (Schäfer et al., 2007). By contrast, *nkx2.9*-positive cells might be post-mitotic precursors that differentiate into *tal2*- and *sim1*-expressing neurons. Consistent with this notion, *tal2*-expressing cells do not express *foxa2* and have exited the cell cycle (Schäfer et al., 2007).

### The regulatory hierarchy leading to KA'' and V3 interneurons

The expression of *nkx2.2a*, *nkx2.2b* and *nkx2.9* is dependent on Hh signals emitted from the adjacent medial floor plate and from the underlying notochord (Barth and Wilson, 1995; Guner and Karlstrom, 2007; Schäfer et al., 2005; Schäfer et al., 2007; Xu et al., 2006). *nkx2.9* expression is driven by a conserved Shh-dependent enhancer, which binds the Hh transducer Gli, suggesting that *nkx2.9* is a direct target of the Hh signaling cascade (Xu et al., 2006). There is also evidence that *nkx2.2a* in zebrafish and *Nkx2.2* in mouse are direct targets of Hh signaling, with Gli binding sites present in their regulatory regions (Vokes et al., 2007; Xu et al., 2006).

Knockdown of *nkx2.2a*, *nkx2.2b* and *nkx2.9* abolishes *sim1*, *gata2*, *gata3*, *tal2* and *gad67* expression in the lateral floor plate, suggesting that the Nkx2 genes act upstream of these genes (Fig. 10). Ectopic *olig2* expression (see Fig. S1K,L in the supplementary material) and *islet1* expression (L.Y., unpublished) was observed in Nkx2 triple-knockdown embryos, suggesting that lateral floor plate cells take up a motoneuronal fate. It remains to be determined whether any of the affected genes is a direct target of the Nkx2 genes. The observed effects might also be explained by loss of cell identity due to a ventral shift of dorsal cells. Important in this context, however, is the fact that we did not observe activation of *pax6.1* or *pax6.2* in the cells immediately adjacent to the medial floor plate.

Knockdown of *gata2*, but not *gata3*, abolished expression of *tal2* and *gad67* in the lateral floor plate, suggesting that *gata2* acts upstream of *tal2* and *gad67* in KA'' cells (Fig. 10). This was



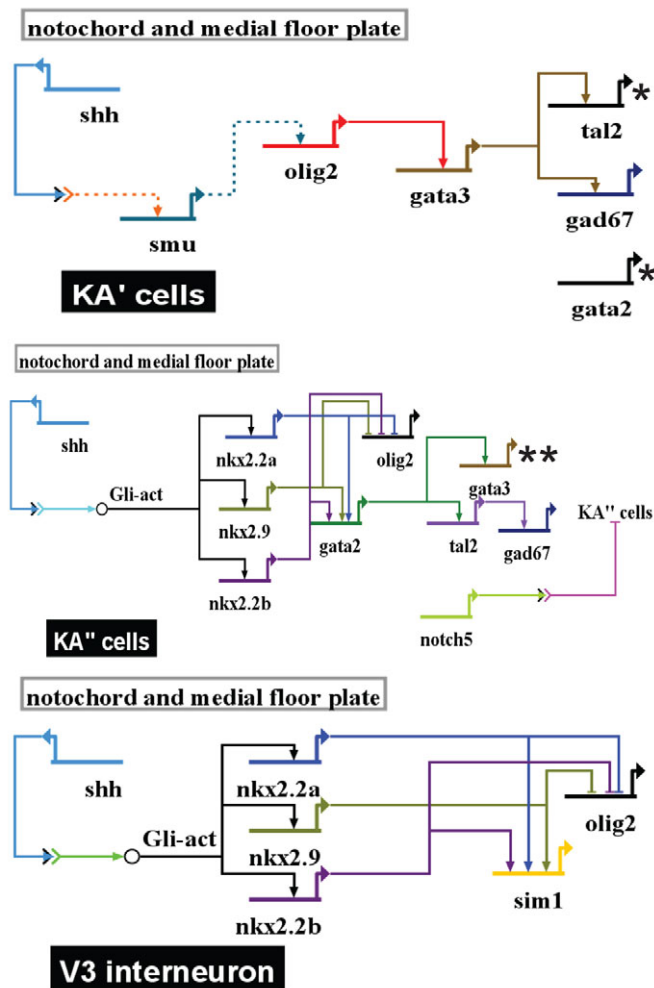

**Fig. 10. Scheme outlining the regulatory interactions in zebrafish KA', KA'' and V3 interneurons.** In the KA' regulatory network (top), *tal2* and *gata2* (single asterisks) are expressed but not functionally linked to *gad67* expression in KA' cells. By contrast, the same two genes control *gad67* expression in KA'' cells (middle). The same reciprocal relationship holds true for *gata3* in KA'' cells (middle, double asterisks): it is expressed in KA'' cells but is not functionally relevant, whereas it is crucial for *gad67* expression in KA' cells. Note that arrows do not necessarily reflect direct interactions of proteins and genes. For details see Discussion.

confirmed by the observation that knockdown of *tal2* did not affect *gata2* or *gata3* expression in the lateral floor plate. Removal of *tal2* activity abolished, however, the expression of *gad67* in the lateral floor plate, placing *tal2* upstream of *gad67* (Fig. 10). Since *gata2*, *tal2* and *gad67* are expressed in the same cells, these interactions could be direct. Indeed, the upstream sequence of the *tal2* gene contains a cluster of Gata2 and Gata3 binding sites (L.Y., unpublished). We cannot exclude, however, additional mediators that act in parallel or in series with Gata2.

Like KA'' cells, V3 interneurons depend on the *nkx2.2a*, *nkx2.2b* and *nkx2.9* genes. We noted co-expression of *tal2* and *sim1* in 25% of cells at 36 hpf, in agreement with previous findings (Schäfer et al., 2007). However, neither *tal2*, *gata2* nor *gata3* knockdown abolished *sim1*-expressing cells in the 48-hour-old spinal cord (L.Y., unpublished). Although both V3 and KA'' cells depend on

the three *Nkx2* genes, the two cell types employ different downstream regulators for further differentiation (Fig. 10). It remains to be elucidated whether the minor fraction of cells (25%) that co-express *sim1* and *tal2* in the lateral floor plate at 36 hpf represent a transitory state in the switch from one differentiation program to the other or an as yet uncharacterized distinct cell type.

### Specification of KA' cells

The ventral half of the zebrafish spinal cord contains two other GABAergic inhibitory interneuron classes: VeLD/V2b and KA' (Bernhardt et al., 1992; Park et al., 2004; Batista et al., 2008). The KA' cells, which are located in the immediate vicinity of the motoneurons, depend on *olig2* function and express *gata2*, *gata3*, *tal2* and *gad67* (Batista et al., 2008) (Fig. 10). As shown by analysis of *olig2:gfp* transgene expression, KA' interneurons appear to be derived from progenitors in the motoneuron domain (Park et al., 2004). Differentiation of GABAergic KA' cells requires *gata3* function. However, knockdown of *gata3* does not seem to abolish *gad67* in VeLD/V2b cells (L.Y., unpublished), suggesting that the functional connections of the regulatory genes differ in KA' and VeLD/V2b cells. *gata3* expression is dependent on *olig2* in KA' cells, indicating that *olig2* acts upstream of *gata3* on *gad67* expression in KA' cells (Fig. 10).

Whereas knockdown of *olig2* abolished KA' cells, ventrally located KA'' cells were slightly increased in abundance. This is in agreement with previous findings that showed that the *olig2*-dependent motoneuron domain produces the Notch ligand jagged 2, which maintains the proliferating precursors in the lateral floor plate cells via activation of Notch5 (Notch3 – Zebrafish Information Network) (Yeo and Chitnis, 2007).

Although *gata2* and *tal2* are both expressed in KA' neurons, their knockdown does not affect the differentiation of these neurons, suggesting that the two genes are not required for *gad67* expression in KA' cells. This is in striking contrast to KA'' cells, in which *gata2* and *tal2* are instrumental for *gad67* expression and/or cell differentiation. KA' and KA'' cells also differ with respect to their dependence on *olig2* expression and their origin in the spinal cord: whereas KA'' cells are derivatives of the lateral floor plate, the KA' cells originate from the motoneuron compartment (Park et al., 2004). Moreover, for *gad67* expression and/or the differentiation of KA' cells, *gata3* and *olig2*, but not *tal2* and *gata2*, are required, even though the latter are expressed in KA' cells. Conversely, in KA'' cells, *gata2* and *tal2* are responsible for *gad67* expression (Fig. 10). Our data imply that *gad67* relies on different regulatory elements for its expression in KA' versus KA'' cells. Our data also suggest that the cis-regulatory elements that mediate activation via the Gata2/Tal2 pathway must be silenced in KA' cells, otherwise the Tal2/Gata2 and Olig2/Gata3 pairs would act redundantly. This implies that the lineage and epigenetic history, and not the expression state of transcription factors, determine which regulatory network controls expression of the differentiation marker *gad67*.

### Acknowledgements

We thank N. Borel and her fish house team, M. Rastegar for help with microscopy, T. Dickmeis and O. Armant for comments and the E. Davidson lab. for BioTapestry. This work was supported by the Helmholtz Association and the European Commission (ZF-MODELS, EUTRACC and NeuroXsys).

### Competing interests statement

The authors declare no competing financial interests.

### Supplementary material

Supplementary material for this article is available at <http://dev.biologists.org/lookup/suppl/doi:10.1242/dev.048470/-/DC1>

## References

- Barth, K. A. and Wilson, S. W. (1995). Expression of zebrafish nk2.2 is influenced by sonic hedgehog/vertebrate hedgehog-1 and demarcates a zone of neuronal differentiation in the embryonic forebrain. *Development* **121**, 1755-1768.
- Batista, M. F., Jacobstein, J. and Lewis, K. E. (2008). Zebrafish V2 cells develop into excitatory CiD and Notch signalling dependent inhibitory VeLD interneurons. *Dev. Biol.* **322**, 263-275.
- Bernhardt, R. R., Patel, C. K., Wilson, S. W. and Kuwada, J. Y. (1992). Axonal trajectories and distribution of GABAergic spinal neurons in wildtype and mutant zebrafish lacking floor plate cells. *J. Comp. Neurol.* **326**, 263-272.
- Briscoe, J. and Ericson, J. (2001). Specification of neuronal fates in the ventral neural tube. *Curr. Opin. Neurobiol.* **11**, 43-49.
- Briscoe, J., Sussel, L., Serup, P., Hartigan-O'Connor, D., Jessell, T. M., Rubenstein, J. L. and Ericson, J. (1999). Homeobox gene *Nkx2.2* and specification of neuronal identity by graded Sonic hedgehog signalling. *Nature* **398**, 622-627.
- Cheesman, S. E., Layden, M. J., Von Ohlen, T., Doe, C. Q. and Eisen, J. S. (2004). Zebrafish and fly *Nkx6* proteins have similar CNS expression patterns and regulate motoneuron formation. *Development* **131**, 5221-5232.
- Detrich, H. W., 3rd, Kieran, M. W., Chan, F. Y., Barone, L. M., Yee, K., Rundstadler, J. A., Pratt, S., Ransom, D. and Zon, L. I. (1995). Intraembryonic hematopoietic cell migration during vertebrate development. *Proc. Natl. Acad. Sci. USA* **92**, 10713-10717.
- Fan, C. M., Kuwana, E., Bulfone, A., Fletcher, C. F., Copeland, N. G., Jenkins, N. A., Crews, S., Martinez, S., Puelles, L., Rubenstein, J. L. et al. (1996). Expression patterns of two murine homologs of *Drosophila* single-minded suggest possible roles in embryonic patterning and in the pathogenesis of Down syndrome. *Mol. Cell. Neurosci.* **7**, 1-16.
- Galloway, J. L., Wingert, R. A., Thisse, C., Thisse, B. and Zon, L. I. (2005). Loss of *gata1* but not *gata2* converts erythropoiesis to myelopoiesis in zebrafish embryos. *Dev. Cell* **8**, 109-116.
- Guner, B. and Karlstrom, R. O. (2007). Cloning of zebrafish *nkx6.2* and a comprehensive analysis of the conserved transcriptional response to Hedgehog/Gli signaling in the zebrafish neural tube. *Gene Expr. Patterns* **7**, 596-605.
- Hadzhiev, Y., Lang, M., Ertzer, R., Meyer, A., Strahle, U. and Müller, F. (2007). Functional diversification of sonic hedgehog paralogs identified by phylogenomic reconstruction. *Genome Biol.* **8**, R106.
- Ingham, P. W. and McMahon, A. P. (2001). Hedgehog signaling in animal development: paradigms and principles. *Genes Dev.* **15**, 3059-3087.
- Jessell, T. M. (2000). Neuronal specification in the spinal cord: inductive signals and transcriptional codes. *Nat. Rev. Genet.* **1**, 20-29.
- Karlstrom, R. O., Talbot, W. S. and Schier, A. F. (1999). Comparative synteny cloning of zebrafish *you-too*: mutations in the Hedgehog target *gli2* affect ventral forebrain patterning. *Genes Dev.* **13**, 388-393.
- Karlstrom, R. O., Tyurina, O. V., Kawakami, A., Nishioka, N., Talbot, W. S., Sasaki, H. and Schier, A. F. (2003). Genetic analysis of zebrafish *gli1* and *gli2* reveals divergent requirements for gli genes in vertebrate development. *Development* **130**, 1549-1564.
- Kimmel, C. B., Ballard, W. W., Kimmel, S. R., Ullmann, B. and Schilling, T. F. (1995). Stages of embryonic development of the zebrafish. *Dev. Dyn.* **203**, 253-310.
- Kucenas, S., Takada, N., Park, H. C., Woodruff, E., Brodie, K. and Appel, B. (2008). CNS-derived glia ensheath peripheral nerves and mediate motor root development. *Nat. Neurosci.* **11**, 143-151.
- Lewis, K. E. and Eisen, J. S. (2003). From cells to circuits: development of the zebrafish spinal cord. *Prog. Neurobiol.* **69**, 419-449.
- Martin, S. C., Heinrich, G. and Sandell, J. H. (1998). Sequence and expression of glutamic acid decarboxylase isoforms in the developing zebrafish. *J. Comp. Neurol.* **396**, 253-266.
- Oxtoby, E. and Jowett, T. (1993). Cloning of the zebrafish *krox-20* gene (*krx-20*) and its expression during hindbrain development. *Nucleic Acids Res.* **21**, 1087-1095.
- Pabst, O., Rummelies, J., Winter, B. and Arnold, H. H. (2003). Targeted disruption of the homeobox gene *Nkx2.9* reveals a role in development of the spinal accessory nerve. *Development* **130**, 1193-1202.
- Park, H. C., Shin, J. and Appel, B. (2004). Spatial and temporal regulation of ventral spinal cord precursor specification by Hedgehog signaling. *Development* **131**, 5959-5969.
- Pinheiro, P., Gering, M. and Patient, R. (2004). The basic helix-loop-helix transcription factor, *Tal2*, marks the lateral floor plate of the spinal cord in zebrafish. *Gene Expr. Patterns* **4**, 85-92.
- Schäfer, M., Kinzel, D., Neuner, C., Schartl, M., Volff, J. N. and Winkler, C. (2005). Hedgehog and retinoid signalling confines *nkx2.2b* expression to the lateral floor plate of the zebrafish trunk. *Mech. Dev.* **122**, 43-56.
- Schäfer, M., Kinzel, D. and Winkler, C. (2007). Discontinuous organization and specification of the lateral floor plate in zebrafish. *Dev. Biol.* **301**, 117-129.
- Stoeckel, M. E., Uhl-Bronner, S., Hugel, S., Veinante, P., Klein, M. J., Mutterer, J., Freund-Mercier, M. J. and Schlichter, R. (2003). Cerebrospinal fluid-contacting neurons in the rat spinal cord, a gamma-aminobutyric acidergic system expressing the P2X2 subunit of purinergic receptors, PSA-NCAM, and GAP-43 immunoreactivities: light and electron microscopic study. *J. Comp. Neurol.* **457**, 159-174.
- Strahle, U., Lam, C. S., Ertzer, R. and Rastegar, S. (2004). Vertebrate floor-plate specification: variations on common themes. *Trends Genet.* **20**, 155-162.
- Vokes, S. A., Ji, H., McCuine, S., Tenzen, T., Giles, S., Zhong, S., Longabaugh, W. J., Davidson, E. H., Wong, W. H. and McMahon, A. P. (2007). Genomic characterization of Gli-activator targets in sonic hedgehog-mediated neural patterning. *Development* **134**, 1977-1989.
- Westerfield, M. (1993). *The Zebrafish Book*. Eugene, OR: University of Oregon Press.
- Wyart, C., Del Bene, F., Warp, E., Scott, E. K., Trauner, D., Baier, H. and Isacoff, E. Y. (2009). Optogenetic dissection of a behavioural module in the vertebrate spinal cord. *Nature* **461**, 407-410.
- Xu, J., Srinivas, B. P., Tay, S. Y., Mak, A., Yu, X., Lee, S. G., Yang, H., Govindarajan, K. R., Leong, B., Bourque, G. et al. (2006). Genomewide expression profiling in the zebrafish embryo identifies target genes regulated by Hedgehog signaling during vertebrate development. *Genetics* **174**, 735-752.
- Yan, Y. L., Willoughby, J., Liu, D., Crump, J. G., Wilson, C., Miller, C. T., Singer, A., Kimmel, C., Westerfield, M. and Postlethwait, J. H. (2005). A pair of *Sox*: distinct and overlapping functions of zebrafish *sox9* co-orthologs in craniofacial and pectoral fin development. *Development* **132**, 1069-1083.
- Yeo, S. Y. and Chitnis, A. B. (2007). Jagged-mediated Notch signaling maintains proliferating neural progenitors and regulates cell diversity in the ventral spinal cord. *Proc. Natl. Acad. Sci. USA* **104**, 5913-5918.
- Zannino, D. A. and Appel, B. (2009). Olig2+ precursors produce abducens motor neurons and oligodendrocytes in the zebrafish hindbrain. *J. Neurosci.* **29**, 2322-2333.
- Zhang, Y., Narayan, S., Geiman, E., Lanuza, G. M., Velasquez, T., Shanks, B., Akay, T., Dyck, J., Pearson, K., Gosgnach, S. et al. (2008). V3 spinal neurons establish a robust and balanced locomotor rhythm during walking. *Neuron* **60**, 84-96.