

Secreted FGFR3, but not FGFR1, inhibits lens fiber differentiation

Venkatesh Govindarajan and Paul A. Overbeek*

Department of Molecular and Cellular Biology, Baylor College of Medicine, Houston, TX 77030, USA

*Author for correspondence (e-mail: overbeek @bcm.tmc.edu)

Accepted 31 January; published on WWW 5 April 2001

SUMMARY

The vertebrate lens has a distinct polarity with cuboidal epithelial cells on the anterior side and differentiated fiber cells on the posterior side. It has been proposed that the anterior-posterior polarity of the lens is imposed by factors present in the ocular media surrounding the lens (aqueous and vitreous humor). The differentiation factors have been hypothesized to be members of the fibroblast growth factor (FGF) family. Though FGFs have been shown to be sufficient for induction of lens differentiation both in vivo and in vitro, they have not been demonstrated to be necessary for endogenous initiation of fiber cell differentiation. To test this possibility, we have generated transgenic mice with ocular expression of secreted self-dimerizing versions of FGFR1 (FR1) and FGFR3 (FR3). Expression of FR3, but not FR1, leads to an expansion of proliferating epithelial cells from the anterior to the posterior side of the lens due to a delay in the initiation of

fiber cell differentiation. This delay is most apparent postnatally and correlates with appropriate changes in expression of marker genes including *p57^{KIP2}*, *Maf* and *Prox1*. Phosphorylation of Erk1 and Erk2 was reduced in the lenses of FR3 mice compared with nontransgenic mice. Though differentiation was delayed in FR3 mice, the lens epithelial cells still retained their intrinsic ability to respond to FGF stimulation. Based on these results we propose that the initiation of lens fiber cell differentiation in mice requires FGF receptor signaling and that one of the lens differentiation signals in the vitreous humor is a ligand for FR3, and is therefore likely to be an FGF or FGF-like factor.

Key words: FGF, FGFR1, FGFR3, Lens, Differentiation, Transgenic mice

INTRODUCTION

In vertebrates, the lens is formed as a result of inductive interactions between the optic vesicle and head ectoderm. Following induction, the head ectoderm thickens to form a lens placode, and subsequently the placode invaginates and pinches off to form the lens vesicle. The newly formed lens acquires a distinct polarity that is maintained throughout life: the anterior cells are maintained as proliferating epithelial cells with cuboidal morphology, while the posterior cells are induced to differentiate as fiber cells with columnar morphology. It has been proposed that the differentiation signal that induces the epithelial cells to differentiate into fiber cells is a diffusible factor that is made and secreted into the vitreous humor by the neural retina (McAvoy et al., 1999). Both in vitro and in vivo studies have implicated fibroblast growth factors (FGFs) in this process (McAvoy and Chamberlain, 1989; Chow et al., 1995; Robinson et al., 1995a; Robinson et al., 1995b; Lovicu and Overbeek, 1998; Robinson et al., 1998; Stolen and Griep, 2000).

The FGF family has at least 23 different members and FGFs have been shown to be involved in various aspects of mammalian development (Martin, 1998). FGFs bind to and signal through low- and high-affinity FGF receptors (FGFRs) (Szebenyi and Fallon, 1999). To date, four high-affinity FGF receptors (FGFR1-FGFR4) have been identified. They are all

structurally similar transmembrane receptor tyrosine kinases. The extracellular portions of the receptors contain two or three immunoglobulin-like motifs (Ig loops) that are important for ligand binding. With the exception of FGFR4, the C-terminal half of the third immunoglobulin loop of the receptors is encoded by alternatively spliced exons resulting in either the IIIb or the IIIc splice forms (Szebenyi and Fallon, 1999). These splice forms of each receptor differ in their ligand binding specificity (Ornitz et al., 1996). For instance, FGFR2IIIb binds to FGF7 and FGF10 but not FGF5 and FGF6. FGFR2IIIc binds to FGF1 and FGF4 but not FGF7 and FGF10 (Ornitz et al., 1996).

Various FGFs and their receptors have been shown to be expressed in the murine eye. The FGFs that are expressed in the eye include FGF1, 2, 3, 5, 7, 10, 11, 12, 13 and 15. FGF1 and FGF2 are expressed in the developing lens (de Jongh and McAvoy, 1993; Lovicu et al., 1997); FGF2, 3, 5, 11, 12, 13 and 15 are expressed in the retina (Wilkinson et al., 1989; Kitaoka et al., 1994; Smallwood et al., 1996; McWhirter et al., 1997); FGF7 and FGF10 are expressed in periorbital mesenchymal cells (Govindarajan et al., 2000). The FGF receptors that are expressed in the lens include FGFR1, FGFR2 and FGFR3 (de Jongh et al., 1996; de Jongh et al., 1997).

Addition of FGFs to rodent lens epithelial explants induces cellular responses in a dose-dependant manner (McAvoy and Chamberlain, 1989). Lower doses of FGFs induce the

epithelial cells to proliferate and higher doses of FGFs induce the epithelial cells to differentiate into fiber cells (McAvoy and Chamberlain, 1989). Similarly, FGFs can induce lens differentiation in vivo: lens-specific expression of certain members of the FGF family induces premature differentiation of the epithelial cells (Robinson et al., 1995b; Lovicu and Overbeek, 1998; Robinson et al., 1998). Although these results show that FGFs are sufficient for induction of the lens differentiation program, it has not yet been shown that FGFs provide the endogenous signals for initiation of lens differentiation. Targeted knockouts of FGFs and their receptors have not clarified this problem, as the mutations have not resulted in any ocular abnormalities, or have caused embryonic lethality prior to lens polarization (Mansour et al., 1993; Hebert et al., 1994; Feldman et al., 1995; Guo et al., 1996; Floss et al., 1997; Dono et al., 1998; Meyers et al., 1998; Min et al., 1998; Ortega et al., 1998; Sekine et al., 1999). Studies of FGFR1 and FGFR3 knockout mice, including chimeric analyses, suggest that these receptors are not necessary for fiber cell differentiation (Deng et al., 1994; Yamaguchi et al., 1994). FGFR2 knockouts die at E9.5-E10.5 (Arman et al., 1998; Xu et al., 1998), so it is not yet clear if FGFR2 is required for eye development. Other experiments performed to inhibit FGF signaling in the lens include lens fiber-specific expression of membrane-bound truncated versions of FGFR1 (lacking the intracellular domain). The lens fiber cells in these transgenic mice show defects in elongation, denucleation and survival (Chow et al., 1995; Robinson et al., 1995a; Stolen and Griep, 2000). Based on these results it was suggested that FGFR signaling is important for fiber cell maturation (Chow et al., 1995; Robinson et al., 1995a; Stolen and Griep, 2000). One of the drawbacks of these studies was that the truncated receptors were not secreted and were expressed only after differentiation had already been initiated (Chow et al., 1995; Robinson et al., 1995a; Stolen and Griep, 2000); so, these studies did not address the question of whether FGF signaling is necessary for initiation of fiber cell differentiation. In this study we have expressed secreted self-dimerizing versions of FGFR1 (FR1) and FGFR3 (FR3) in the lens. The secreted FGF receptors should bind to and sequester the endogenous FGFs present in the vitreous humor and thereby interfere with their biological activity. Our studies show that expression of FR3, but not FR1, causes the zone of fiber cell induction (transition zone) to move to the posterior tip of the lens. Altered spatial expression patterns of *p57^{KIP2}* (*Cdkn1c* – Mouse Genome Informatics), *Maf* and *Prox1* are consistent with a delay in initiation of fiber cell differentiation. In addition, phosphorylation of the signal transduction proteins Erk1 and Erk2 is reduced in the lenses of FR3 mice. The delay in initiation of fiber cell differentiation in FR3 mice can be rescued by extra FGF stimulation, implying that the epithelial cells have retained their ability to respond to FGF stimulation. These results indicate that the endogenous lens differentiation signal in the vitreous humor is an FGF or FGF-like molecule.

MATERIALS AND METHODS

Construction of the transgenes

Secreted self-dimerizing versions of mouse FGFR1 (FR1) and FGFR3 (FR3) (Ye et al., 1998) encoding the extracellular domains of the

receptors fused to the Fc domain of rat immunoglobulins were provided by Dr Arnon Rosenthal (Genentech, San Francisco). Both versions of the receptors lack the intracellular and transmembrane domains and are three loop versions of the 'c' splice form. The FR1 cDNA was inserted into *HindIII* and *EcoRI* restriction sites between the α A-crystallin promoter (Overbeek et al., 1985) and the small t intron/polyadenylation sequences of the CPV2 vector (Reneker et al., 1995) (Fig. 1). The FR3 cDNA was excised by *HindIII* and *Clal* restriction digestion, blunt-ended and inserted into the *EcoRV* site of the CPV2 vector (Fig. 1). Both FR1 (2.95 kb) and FR3 (2.9 kb) transgenes were released from the CPV2 vector by *NotI* digestion, gel purified using the QiaexII gel extraction kit (Qiagen, Hilden, Germany) and used for microinjections. Transgenic mice were generated and founders were screened as described previously (Lovicu and Overbeek, 1998).

Histological analyses

Histological analyses were performed using standard histological techniques as described previously (Lovicu and Overbeek, 1998).

In situ hybridizations

To analyze expression of the transgenes, a [³⁵S] UTP-labeled riboprobe specific to the SV40 sequences of the transgenes was made (see Fig. 1). Expression of *p57^{KIP2}*, *Maf* and *Prox1* was analyzed using [³⁵S]-labeled riboprobes made from the corresponding mouse cDNAs. The *p57^{KIP2}* antisense probe was synthesized using *BamHI*-digested cDNA (kindly provided by Dr Steve Elledge, Baylor College of Medicine, Houston) and T3 RNA polymerase (Promega). The antisense probe for *Maf* was synthesized using *HindIII*-digested mouse *Maf* cDNA (kindly provided by Drs Brian Ring and Gregory Barsh, Stanford University) and T7 RNA polymerase. The antisense probe for *Prox1* (kindly provided by Dr Guillermo Oliver, St Jude's Children's Hospital) was synthesized using *BglIII*-digested DNA and T3 RNA polymerase. In situ hybridization of tissue sections was as described previously (Robinson et al., 1995b). The hybridized slides were soaked in Kodak NTB-2 emulsion, dried and exposed for 3-7 days at 4°C. Following development and fixation, the slides were counterstained with Hematoxylin.

Immunohistochemistry

Immunohistochemistry on paraffin-embedded tissue sections was performed as follows. Slides containing ocular sections were deparaffinized, hydrated and preincubated with 10% methanol and 3% H₂O₂ in phosphate-buffered saline (PBS) or tris-buffered saline (TBS). The antigens were retrieved by treatment with Ficin (Sigma), diluted 1:100 in PBS and incubated at 37°C for 30 minutes. Following antigen retrieval, the tissue sections were blocked with 3% normal horse serum for 1 hour, at room temperature. The slides were then incubated with an anti-rat Fc antibody (Vector Laboratories) (1:100) overnight at 4°C. After brief washes in PBS, the slides were incubated with the appropriate biotinylated-secondary antibody for 1 hour at 37°C. Antigen-antibody complexes were then detected using streptavidin-linked horseradish peroxidase and diaminobenzidine tetrahydrochloride (DAB), according to the manufacturer's specifications (Vector Laboratories). After color development, the slides were counterstained with Hematoxylin. DNA replication was examined by BrdU incorporation as described previously (Lovicu and Overbeek, 1998).

RT-PCR

RT-PCR was as described previously (Reneker et al., 1995). The primers used for amplification of α A, β A4, β B3 crystallins and β -actin have been described previously (Ring et al., 2000). The primers used for amplification of α B, γ A, γ D crystallins and Hprt are as described (Nishiguchi et al., 1998). Serial dilutions (1:10, 1:100, 1:1000) of the reverse transcription reaction were amplified by PCR using the following cycle conditions: 94°C for 30 seconds, 60°C for

1 minute, 72°C for 1 minute, 28 cycles for α A crystallin; 94°C for 30 seconds, 60°C for 1 minute, 72°C for 1 minute, 25 cycles for β A4, β B3 and γ A crystallins; 94°C for 30 seconds, 55°C for 1 minute, 72°C for 1 minute, 28 cycles for α B, γ D crystallins and Hprt; and 94°C for 30 seconds, 50°C for 1 minute, 72°C for 1 minute, 25 cycles for β -actin.

Western blots

For analysis of protein expression, total proteins from lenses (or eyes) of transgenic and control mice were isolated. Tissues were homogenized in a lysis buffer containing 150 mM NaCl, 50 mM Tris pH 7.4, 1% Triton X-100, 1% sodium deoxycholate, 0.1% sodium dodecyl sulfate, protease inhibitors (1 mM PMSF, 1 mg/ml leupeptin, 1.4 mg/ml pepstatin, 400 mM aprotinin), 1 mM EDTA, pH 8.0, 5 mM EGTA pH 8.0. After centrifugation at 16,000 *g* at 4°C, the supernatant was recovered and the protein concentration determined using the BioRad protein assay (BioRad). 100–200 μ g of total lens proteins were denatured in 2 \times SDS sample buffer and boiled. The proteins were resolved by SDS-PAGE, then electrotransferred to PVDF (DuPont) membranes. The blots were blocked with 3% BSA in Tris-buffered saline with Tween-20 (TBST) (50 mM Tris pH 7.5, 150 mM NaCl, 0.05% Tween-20) or 5% nonfat dry milk (Carnation) in TBST at 4°C overnight or 2 hours at room temperature. The blots were incubated with the appropriate primary antibody (anti-MAP kinase, 1:3000, UBI; anti-rat Fc, 1:750, Vector Labs; anti-FGFR1 and anti-FGFR3, 1:200, Sigma) for an hour at room temperature or overnight at 4°C (anti-phosphoMAPK, 1:1000, Cell Signaling) and washed three times in TBST. The blots were then incubated with the appropriate secondary antibody, washed, and the antigen-antibody complex was detected by enhanced chemiluminescence (ECL) according to manufacturer's specifications (Amersham). In vitro transcription and translation reactions were performed using Riboprobe systems T3/T7 (Promega) following the manufacturer's instructions.

RESULTS

Generation of transgenic mice

To attempt to block intraocular FGF signaling we generated transgenic mice that express secreted self-dimerizing versions of FGFR1 (FR1) and FGFR3 (FR3) in the lens. The soluble FGF receptors were expected to bind to and sequester endogenous FGFs present in the vitreous humor and thereby block the ability of these FGFs to stimulate the endogenous receptors. Expression of the transgenes was driven by the lens-specific α A-crystallin promoter (Fig. 1; Overbeek et al., 1985). Two founder animals that expressed FR1 were identified by RT-PCR and designated OVE1582 and 1584. These animals did not show any ocular abnormalities. Five founder mice that expressed the FR3 transgene were identified and designated OVE1547, 1548A, 1549, 1550 and 1551. All these transgenic animals displayed ocular defects. The eyes of all these mice were of smaller size than normal and lens cataracts were visible when the mice opened their eyes at postnatal day 14 (P14; data not shown).

Expression of FR3 in the lens delays lens differentiation

Hematoxylin and Eosin staining of eyes from FR3 mice revealed changes in fiber cell differentiation (Fig. 2). At E15, the changes in the lens architecture were subtle. In families OVE1547 and 1548A, the fiber cells had not elongated properly. The fiber cell length was reduced (Fig. 2E,I) suggesting a delay in fiber cell maturation. These changes were not noticed in the other transgenic families (data not shown). In nontransgenic

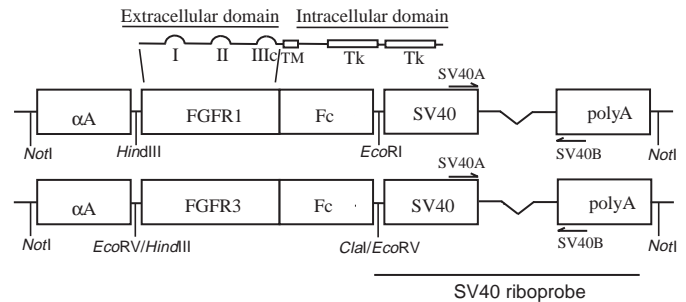

Fig. 1. Schematic representations of FR1 and FR3 transgenes. Extracellular domains of FGFR1 (FR1) and FGFR3 (FR3) fused to the Fc domain of rat immunoglobulin (Ye et al., 1998) were inserted into the CPV2 vector between the α A-crystallin promoter (α A) and an intron and polyadenylation sequence derived from SV40 virus (Reneker et al., 1995). The SV40 sequences were used to make a riboprobe for detection of expression of the transgene. Primers (SV40A and SV40B) used for PCR are indicated. TM, transmembrane domain; Tk, tyrosine kinase domain; I, II, IIIc, immunoglobulin-like domains.

mice, the lens epithelial cells exit the cell cycle and initiate their differentiation program near the equator of the lens in a region termed the transition zone (Fig. 2B–D, red arrowheads). The transition zone migrated to the posterior pole in the lenses of all the FR3 transgenic families (Fig. 2F–H, J–L, N, O, Q, R, red arrowheads) suggesting an inhibition of the initiation of the fiber cell differentiation program. This inhibition was readily apparent by P1 in the families OVE1547 and 1548A (Fig. 2F, J) and by P7 in the families OVE1549 and 1550 (Fig. 2N, O, Q, R).

In addition to the lens defects, there were also changes in the vasculature surrounding the lens (Fig. 2G, K, N, black arrowheads). In nontransgenic mice, most of the hyaloid vasculature has begun to regress by P7 (Fig. 2C). But in the FR3 transgenic mice of the same age, blood vessels were still prevalent (Fig. 2G, K, N, black arrowheads). Other ocular tissues including the cornea and the retina appeared normal.

Levels of transgene expression correlate with the onset of the ocular phenotypes

To confirm lens-specific expression of the transgenes, in situ hybridization was performed on sections of E15 eyes (Fig. 3A) using an SV40 riboprobe (Fig. 1). Hybridization signals were seen exclusively in the fiber cells of the lens (Fig. 3A). Different levels of transgene expression were seen in the different transgenic families: transgenic families OVE1547, 1548A (FR3) and 1584 (FR1) showed higher levels of expression than families OVE1549 and 1550 (FR3). Interestingly, the levels of transgene expression correlated with the time of onset of lenticular changes for the FR3 families.

Expression of the transgenic proteins was examined by western blot analysis of lens lysates from newborn mice. The blots were probed with antibodies raised against the Fc domain of rat immunoglobulins or antibodies raised against the extracellular domains of FGFR1 or FGFR3 (Fig. 3B). The anti-rat Fc antibody detects the Fc domain of the transgenic proteins (Fig. 3B). Blots probed with this antibody showed higher FR3 expression in families OVE1547 and 1548A than in families OVE1549 and 1550 (Fig. 3B, arrows) consistent with their transcript levels. Also, FR1 protein expression in OVE1584 was comparable with the FR3 expression in OVE1547 and 1548A.

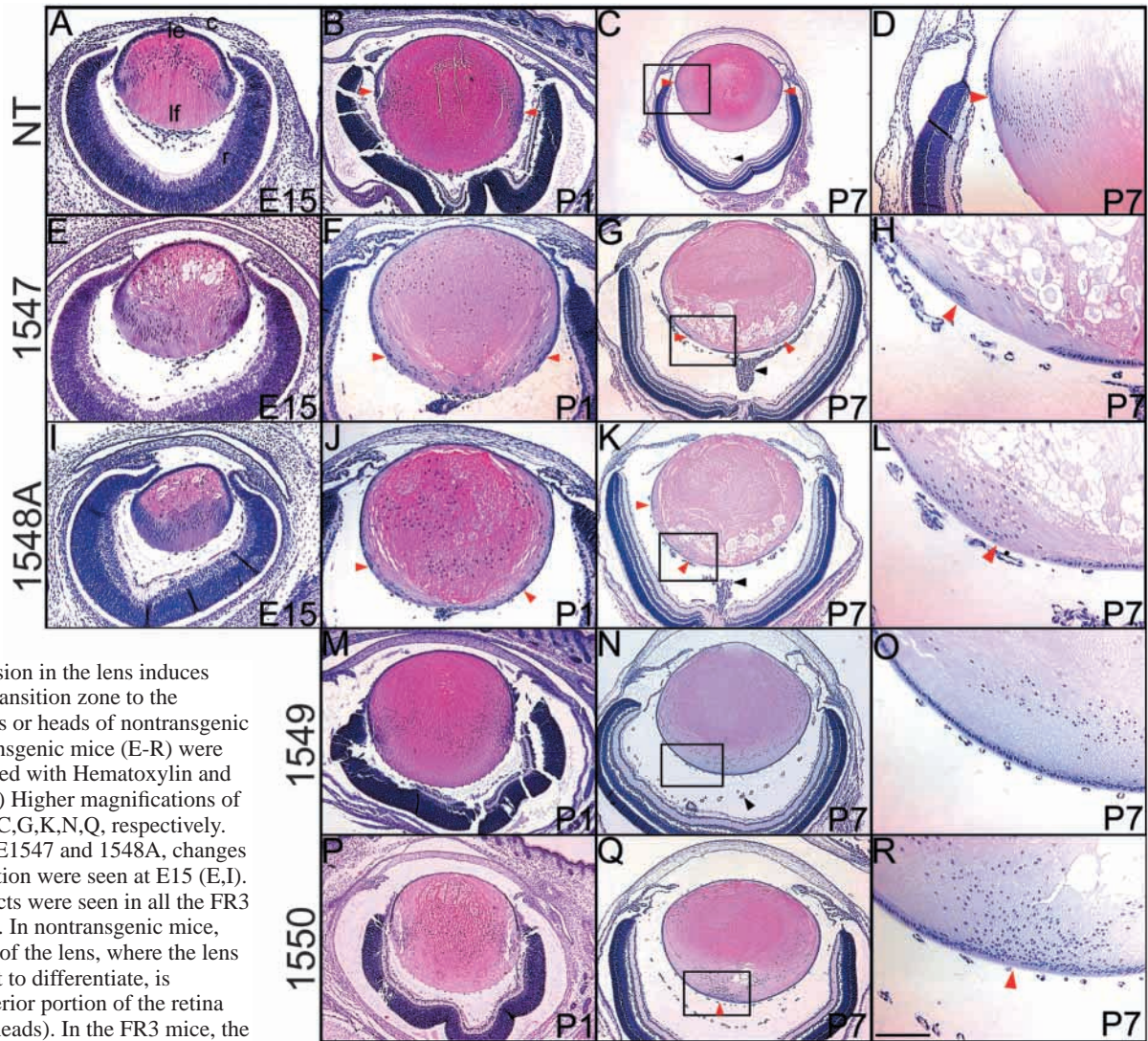

Fig. 2. FR3 expression in the lens induces movement of the transition zone to the posterior pole. Eyes or heads of nontransgenic (A-D) and FR3 transgenic mice (E-R) were sectioned and stained with Hematoxylin and Eosin. (D,H,L,O,R) Higher magnifications of the boxed areas in C,G,K,N,Q, respectively. In the families OVE1547 and 1548A, changes in fiber cell elongation were seen at E15 (E,I). Postnatal lens defects were seen in all the FR3 transgenic families. In nontransgenic mice, the transition zone of the lens, where the lens epithelial cells start to differentiate, is adjacent to the anterior portion of the retina (B,C,D, red arrowheads). In the FR3 mice, the transition zone moves to the posterior pole of the lens (F-H,J-L,N,O,Q,R, red arrowheads). This change is apparent by P1 in the families OVE1547 and 1548A and by P7 in families OVE1549 and 1550. In addition, the hyaloid vasculature surrounding the lens, which normally begins to regress by P7 (C), was seen to persist in the FR3 transgenic families (G,K,N, black arrowheads). Eyes of FR1 transgenic mice did not show any ocular abnormalities (data not shown). NT, nontransgenic; r, retina; le, lens epithelial cells; lf, lens fiber cells; c, cornea. Scale bar: 200 μ m in A,E,F,I,J; 400 μ m in B,G,K,M,N,P,Q; 800 μ m in C; 100 μ m in D; 50 μ m in H,L,O,R. Note that the P7 images of the nontransgenic eyes are shown at 2-fold lower magnification than the transgenic eyes.

Both the FR1 and FR3 transgenic proteins migrated at higher molecular weights than the proteins generated by *in vitro* transcription/translation (Fig. 3B, IVTT) suggesting that the proteins were modified post-translationally *in vivo*. Transgenic protein expression was also confirmed by Western blots probed with antibodies raised against the extracellular domains of mouse FGFR1 and 3 (Fig. 3B). The anti-FGFR1 antibody also detected the endogenous FGFR1 protein(s). Endogenous FGFR3 protein expression was not detected presumably because of lower abundance of the protein, since FGFR3 has been shown previously to be transcribed in the lens (de Jongh et al., 1997).

The spatial localization of the transgenic proteins was examined by immunohistochemical analysis performed on sections of transgenic (OVE1548A and 1584) and nontransgenic E15 heads using the anti-rat Fc antibody (Fig. 3C). Positive staining was seen both in the fiber cells and in

the vitreous humor, suggesting that the fiber cells made and secreted the FR1 and FR3 transgenic proteins into the vitreous humor. These results suggested that the lack of a lens phenotype in the FR1 mice is not due to insufficient expression or secretion of the transgenic FR1 protein. The strongest staining of FR1 and FR3 in the vitreous humor is located at the cell membranes of the vasculature. It is not clear whether this is a fixation artifact (as our fixation protocol does not preserve the architecture of the vitreous humor) or represents a true association of FR1 and FR3 with the vascular cells.

FR3 causes expansion of the proliferating epithelial cells to the posterior region of the lens

To test if expression of FR3 affected proliferation of the lens epithelial cells, sections of eyes from FR1 (P1) and FR3

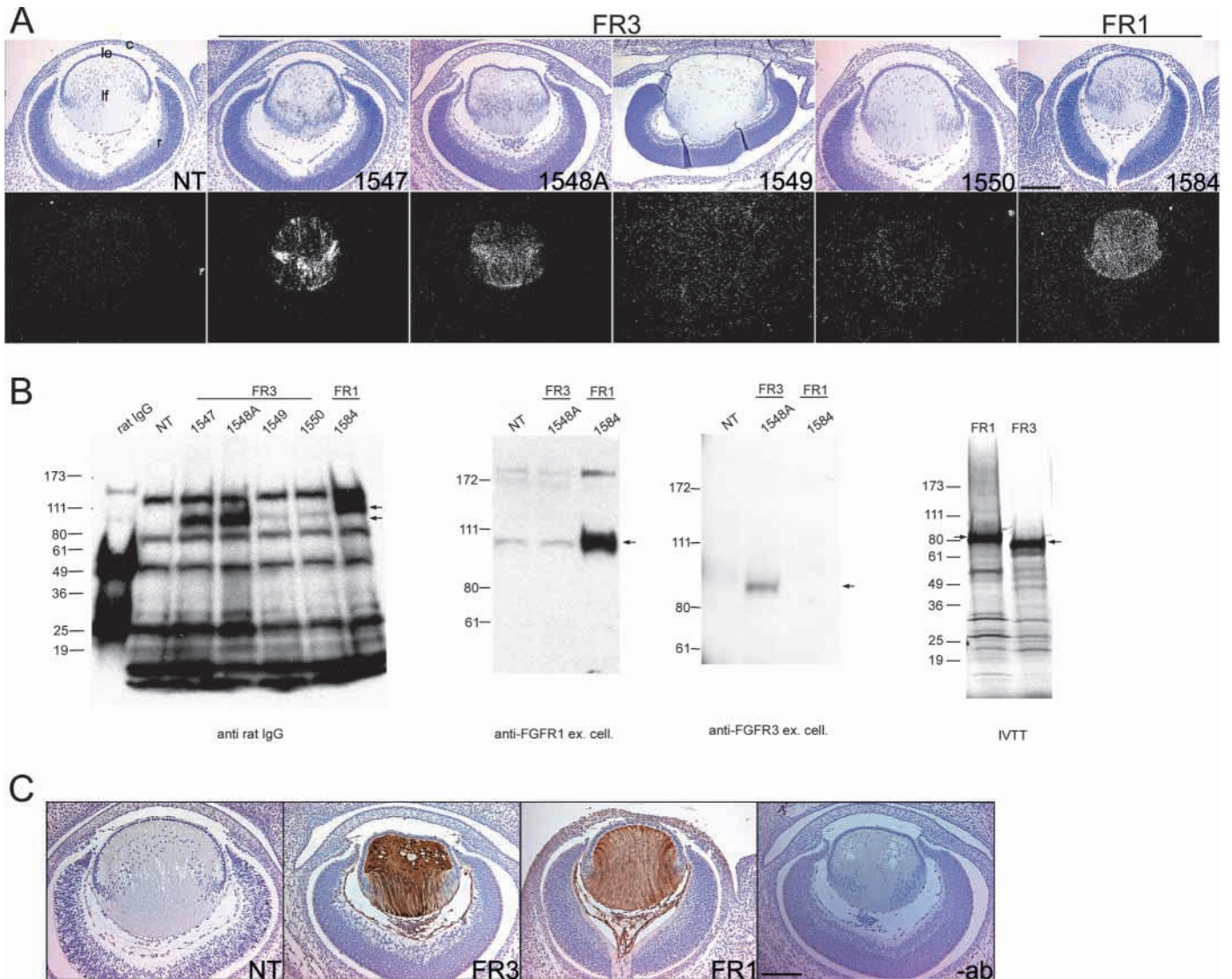

Fig. 3. FR1 and FR3 transgene expression. (A) In situ hybridization of sections of E15 eyes using a [35 S]-labeled SV40 riboprobe. Bright-field and corresponding dark-field images of ocular sections from nontransgenic (NT), OVE1547, 1548A, 1549, 1550 (all FR3) and 1584 (FR1) mice are shown. Transgene expression was fiber cell-specific and the highest levels of transgene expression were seen in the families OVE1547, 1548A and 1584. (B) Western blots on lens lysates from newborn nontransgenic (NT), FR3 and FR1 transgenic mice. The blot on the far left was probed with an antibody that recognizes the Fc domain of the transgenic proteins (arrows). Rat IgG was used as a positive control. Transgenic protein expression in the FR1 mice (OVE1584) was comparable to that of FR3 families OVE1547 and 1548A. The blots in the center were probed with either an anti-FGFR1 or anti-FGFR3 antibody. These antibodies raised against the extracellular domains of mouse FGFR1 and 3 (ex. cell.) also cross react with the corresponding endogenous receptors. The transgenic proteins are expressed at higher levels than the endogenous proteins. In vitro transcription/translation (IVTT) of FR1 and FR3 produces proteins that migrate at lower molecular weights (right panel) than their in vivo counterparts. (C) Immunohistochemical analysis of E15 eyes from nontransgenic (NT), FR3 (OVE1548A) and FR1 (OVE1584) transgenic mice. E15 heads were sectioned and immunostained with the anti-Fc antibody and the antigen antibody complex detected using a peroxidase-conjugated secondary antibody and a DAB substrate. Positive staining (brown color) was seen in the lens fiber cells and in the vitreous humor of FR3 and FR1 mice. As a negative control, the primary antibody was excluded (-ab) from the experimental procedure. r, retina; le, lens epithelial cells; lf, lens fiber cells; c, cornea. Scale bars: 100 μ m.

(P1 and P7) transgenic families were assayed for BrdU incorporation (Fig. 4). In nontransgenic mice, the posterior part of the lens is composed of differentiated fiber cells that do not incorporate BrdU and the anterior part is composed of proliferating epithelial cells (Fig. 4A,D,G,I, black arrowheads). In FR3 mice, the epithelial cells in the posterior part of the lens showed BrdU incorporation (Fig. 4B,E,H,J, black arrowheads) suggesting that these cells had not been induced to exit the cell

cycle and to initiate their differentiation program. Overall, there was a modest decrease in the number of BrdU-positive cells in the FR3 lenses (Table 1) suggesting that the posteriorization of the transition zone in these mice was not caused by increased epithelial cell proliferation. BrdU incorporation in the lenses of FR1 mice was similar to that in nontransgenic mice (Fig. 4C, Table 1).

In the FR3 transgenic mice, the endothelial cells of the

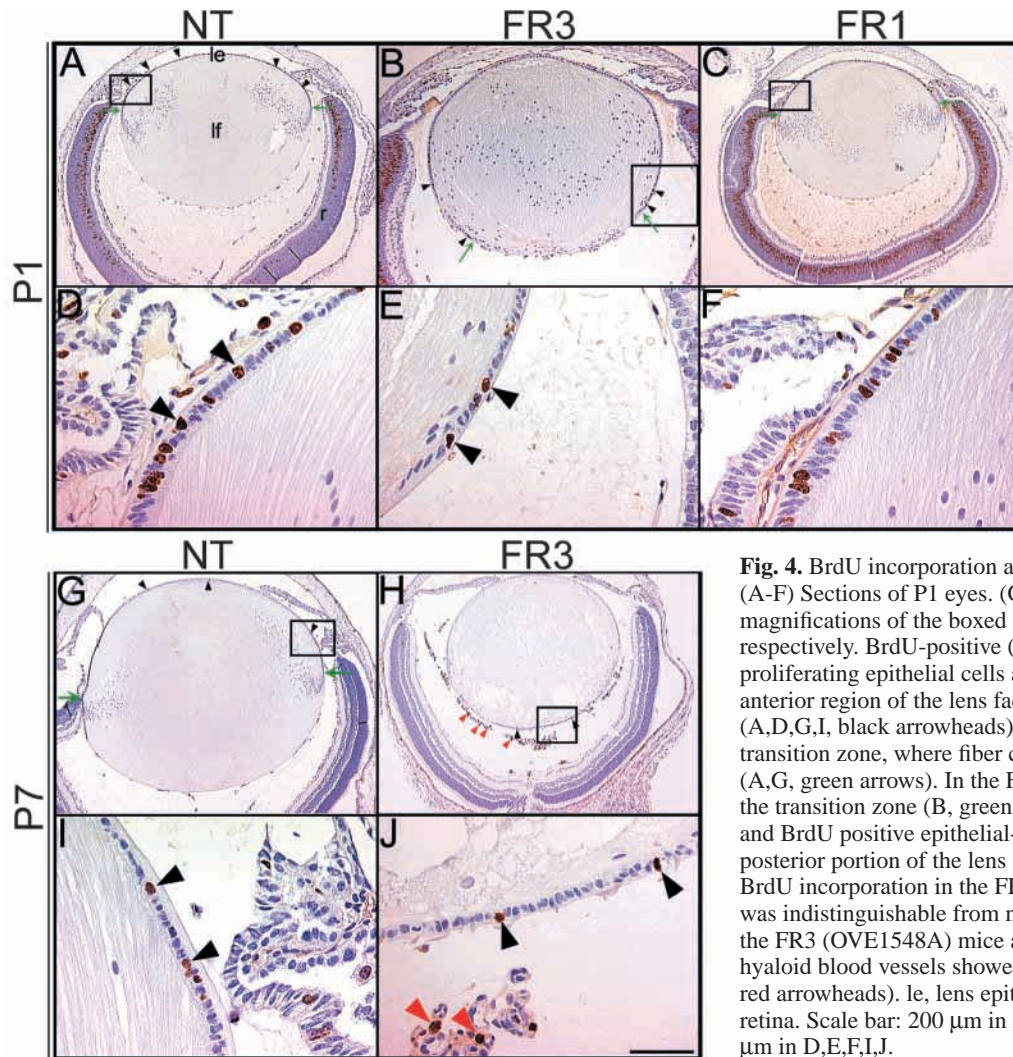

Fig. 4. BrdU incorporation and cell proliferation. (A-F) Sections of P1 eyes. (G-J) P7 eyes. (D-F, I, J) Higher magnifications of the boxed areas in A-C, G, H, respectively. BrdU-positive (brown stained nuclei) proliferating epithelial cells are normally restricted to the anterior region of the lens facing the aqueous humor (A, D, G, I, black arrowheads). Cell cycle exit occurs at the transition zone, where fiber cell differentiation is initiated (A, G, green arrows). In the FR3 mice (OVE1548A) mice, the transition zone (B, green arrows) is shifted posteriorly and BrdU positive epithelial-like cells are seen in the posterior portion of the lens (B, E, H, J, black arrowheads). BrdU incorporation in the FR1 (OVE1584) lenses (C, F) was indistinguishable from nontransgenic lenses (A, D). In the FR3 (OVE1548A) mice at P7, endothelial cells of the hyaloid blood vessels showed BrdU incorporation (H, J, red arrowheads). le, lens epithelium, lf, lens fibers, r, retina. Scale bar: 200 μ m in A, C, G, H; 100 μ m in B; 50 μ m in D, E, F, I, J.

postnatal hyaloid vasculature showed BrdU incorporation (Fig. 4H, J, red arrowheads) suggesting that the persistence of this vasculature could be attributable, in part, to inappropriate cell proliferation.

Spatial expression patterns of *p57^{KIP2}*, *Maf* and *Prox1* in FR3 mice

We further analyzed the delay in initiation of fiber cell differentiation by examining the expression patterns of marker genes such as *p57^{KIP2}*, *Maf* and *Prox1* by in situ hybridizations (Fig. 5). Enhanced expression of *p57^{KIP2}*, a cyclin-dependent kinase inhibitor, at the transition zone has been shown to be an essential aspect of fiber cell induction (Zhang et al., 1998). In the lenses of eyes from nontransgenic mice, both at P1 and P7, expression of *p57^{KIP2}* was induced specifically at the transitional zone at the equator of the lens (Fig. 5A, A', D, arrowheads). In FR3 transgenic lenses at P1, induction of *p57* occurred more posteriorly and at P7, expression was seen exclusively at the posterior pole of the lens (Fig. 5B, B', E, E', arrowheads). *Maf* and *Prox1* are two transcription factors that have been shown to be important for initiation and progression of fiber cell differentiation (Wigle et al., 1999; Ring et al., 2000). *Maf* is a basic domain/leucine

zipper domain transcription factor that has been shown to be essential for normal fiber cell differentiation (Ring et al., 2000). *Prox1* is a homeobox gene expressed both in the epithelial and fiber cells with elevated expression at the transitional zone (Fig. 5K, K', N arrowhead). *Prox1* has been shown to be important for *p57^{KIP2}* expression in the lens (Wigle et al., 1999). In the FR3 transgenic mice, the spatial expression patterns of *Maf* (Fig. 5G, G', J, J', arrowheads) and *Prox1* (Fig. 5L, L', O, O', arrowheads) were altered in a pattern similar to *p57^{KIP2}*. The region of induced expression for both transcription factors moved toward the posterior of the lens (Fig. 5G, J, L, O), supporting the notion that there was an inhibition of initiation of fiber cell differentiation.

Table 1. Comparison of lens epithelial cell proliferation

| | Total number of lens epithelial cells | Total number of BrdU-positive cells | BrdU-positive cells (%) | Number of samples |
|-----------------|---------------------------------------|-------------------------------------|-------------------------|-------------------|
| Wild type* | 269 \pm 28 | 29 \pm 2 | 10.6 \pm 0.6 | 3 |
| OVE1548A* (FR3) | 233 \pm 11 | 19 \pm 1 | 8 \pm 0.8 | 4 |
| OVE1584* (FR1) | 219 \pm 28 | 27 \pm 2 | 12.3 \pm 1.6 | 4 |

*Postnatal day 1 mice, nuclei per 5 μ m section.

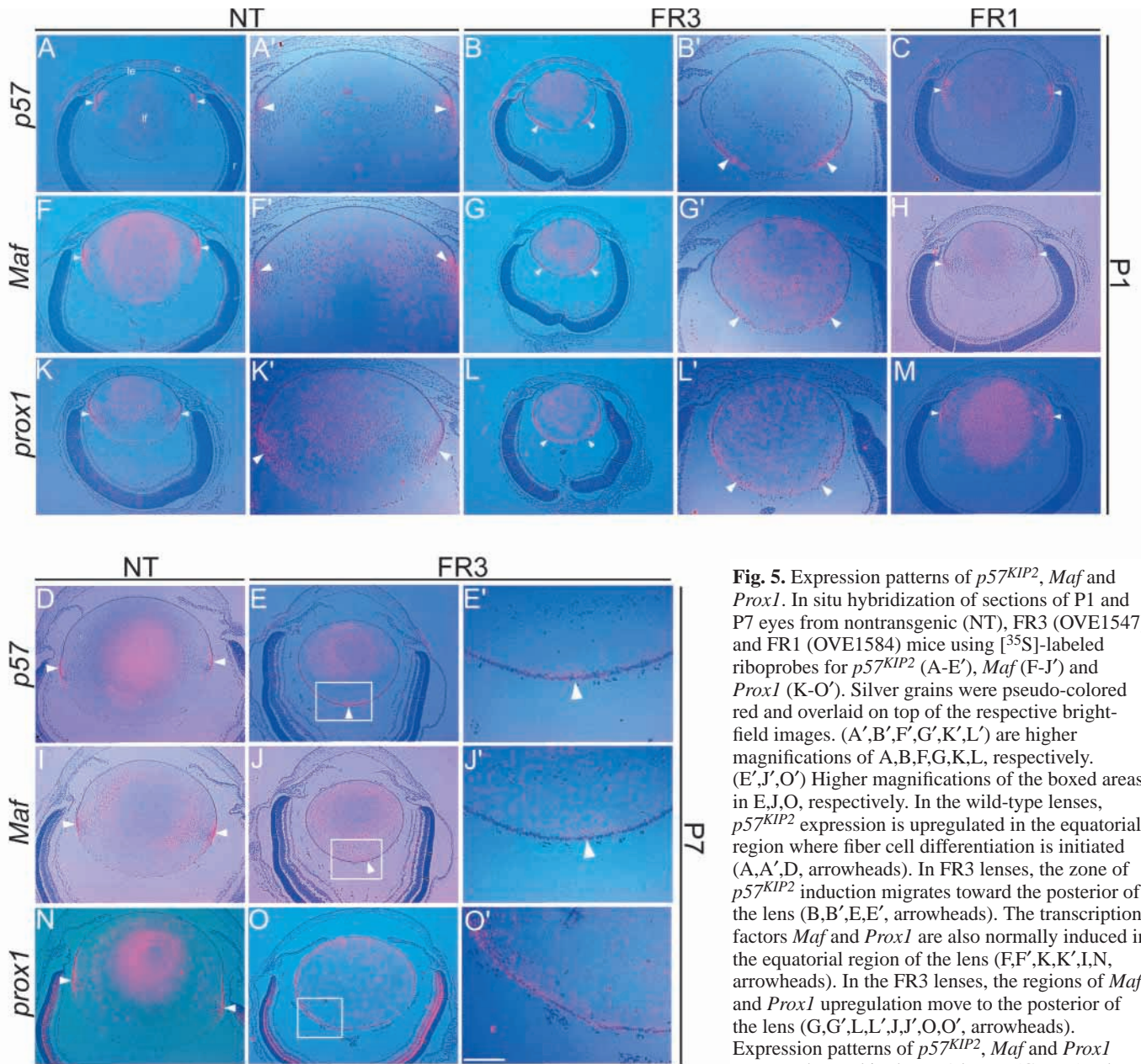

Fig. 5. Expression patterns of *p57^{KIP2}*, *Maf* and *Prox1*. In situ hybridization of sections of P1 and P7 eyes from nontransgenic (NT), FR3 (OVE1547) and FR1 (OVE1584) mice using [³⁵S]-labeled riboprobes for *p57^{KIP2}* (A-E'), *Maf* (F-J') and *Prox1* (K-O'). Silver grains were pseudo-colored red and overlaid on top of the respective bright-field images. (A',B',F',G',K',L') are higher magnifications of A,B,F,G,K,L, respectively. (E',J',O') Higher magnifications of the boxed areas in E,J,O, respectively. In the wild-type lenses, *p57^{KIP2}* expression is upregulated in the equatorial region where fiber cell differentiation is initiated (A,A',D, arrowheads). In FR3 lenses, the zone of *p57^{KIP2}* induction migrates toward the posterior of the lens (B,B',E,E', arrowheads). The transcription factors *Maf* and *Prox1* are also normally induced in the equatorial region of the lens (F,F',K,K',I,N, arrowheads). In the FR3 lenses, the regions of *Maf* and *Prox1* upregulation move to the posterior of the lens (G,G',L,L',J,J',O,O', arrowheads). Expression patterns of *p57^{KIP2}*, *Maf* and *Prox1* were unchanged in the FR1 lenses (C,H,M). The

staining in the core of the lens in D,M,N is an artifact of the dark-field illumination. le, lens epithelium; lf, lens fibers; c, cornea; r, retina. Scale bar: 400 μ m in A-C,F-H,K-M; 200 μ m in A',B',F',G',K',L'; 800 μ m in D,I,N,E,J,O; 50 μ m in E',J',O'.

Crystallin synthesis is not significantly altered in the lenses of FR3 mice

Crystallin transcript levels were compared between nontransgenic and FR3 transgenic mice by semi-quantitative RT-PCR (Fig. 6). Total RNA was isolated from P2 lenses of nontransgenic, FR3 (OVE1548A) and FR1 (OVE1584) mice, reverse transcribed and amplified by PCR. Mouse β -actin and Hprt were used as internal controls. Relative to the controls, crystallin transcript levels were similar between nontransgenic and FR3 lenses (Fig. 6) indicating that the average levels of crystallin transcription per cell were not significantly reduced in the transgenic lenses. These results suggest that at P2, the initiation of fiber cell differentiation is delayed but not

completely blocked and the differentiating fiber cells are not undergoing rapid degeneration.

Decrease in MAPK phosphorylation in FR3 mice

To analyze changes in FGF signaling in the lens, we examined changes in the phosphorylation state of mitogen-activated protein kinases (MAP kinases), downstream targets of FGF signaling (Szebenyi and Fallon, 1999). Stimulation of FGF receptors can induce the activation of the Ras-Raf signaling pathway leading to phosphorylation of the MAP kinases (Szebenyi and Fallon, 1999). As FGF signaling was predicted to be blocked in the lenses of FR3 transgenic mice, MAP kinase phosphorylation was predicted to be decreased. To test

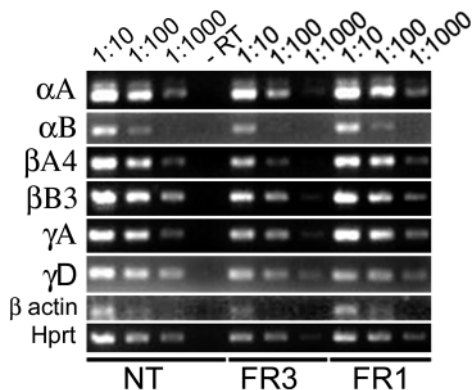

Fig. 6. Crystallin expression. Semi-quantitative RT-PCR was used to look for changes in the expression of α A, α B, β A4, β B3, γ A and γ D crystallins in the lenses of nontransgenic (NT), FR3 (OVE1548A) and FR1 (OVE1584) mice as described in Materials and Methods. Serial dilutions of the reverse transcription reactions were made in the ratios 1:10, 1:100 and 1:1000. β -actin and Hprt were used as internal controls. Expression levels of the crystallins were at most modestly reduced in the FR3 mice.

this hypothesis, proteins were isolated from lenses of nontransgenic, FR3 (OVE1548A) and FR1 (OVE1584) newborn mice, resolved by SDS-PAGE, blotted and probed with an antibody against phosphorylated MAP kinase that cross reacts with both Erk1 and Erk2. As an internal control, a duplicate blot was probed with an antibody that recognizes both the unphosphorylated and phosphorylated versions of Erk1 and Erk2. This analysis showed decreased levels of phosphorylation of Erk1 and Erk2 in FR3 mice (Fig. 7) suggesting that endogenous FGFR signaling in the lens was blocked in the FR3 mice.

Lens epithelial cells in FR3 mice are competent to respond to FGF stimulation

To determine if the delay in lens fiber differentiation in FR3 mice was due to loss of the intrinsic ability of the epithelial cells to respond to FGF stimulation, FR3 mice were crossed with transgenic mice that express FGF8 or FGF7 in their lenses (Lovicu and Overbeek, 1998). Histological analysis was performed on P1 or P14 eyes of mice that expressed one or both of the transgenes (Fig. 8). Lens-specific expression of FGF8 induces premature fiber cell elongation (Fig. 8B; Lovicu and Overbeek, 1998). In mice that express both FR3 and FGF8 in the lens, the lens epithelial cells were still induced to elongate and differentiate into fiber cells (Fig. 8C) although the rate of differentiation appeared to be reduced which is consistent with the prediction that FR3 can bind to FGF8 (Ornitz et al., 1996). Lens-specific expression of FGF7 does not induce elongation of the lens epithelial cells but induces the formation of lacrimal gland-like structures in the corneal epithelium (Fig. 8E, arrowheads; Lovicu et al., 1999). The lens morphology of FR3/FGF7 transgenic mice was indistinguishable from that of the FR3 lenses (Fig. 8D,F).

DISCUSSION

Expression of a secreted self-dimerizing FGFR3 (FR3), but not

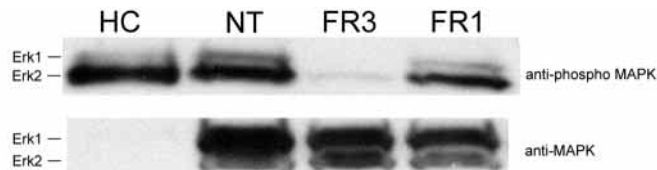

Fig. 7. Phosphorylation of Erk1 and Erk2 in the lens. Western blot analysis of lens lysates from newborn nontransgenic (NT), FR3 (OVE1548A) and FR1 (OVE1584) transgenic mice. Duplicate blots were probed either with the anti-MAP kinase (lower panel) or the anti-phosphoMAP kinase (upper panel) antibody and the antigen-antibody complexes were detected by enhanced chemiluminescence (ECL) as described in Materials and Methods. Stimulated hippocampal cells (HC) were used as a positive control. Erk1 and Erk2 phosphorylation levels were reduced in FR3 mice compared with nontransgenic (NT) and FR1 transgenic mice. Blots probed with the anti-MAP kinase antibody show equal loading of lens proteins.

a comparable FGFR1, in the lens leads to a delay in initiation of fiber cell differentiation. This delay in differentiation is most apparent postnatally. BrdU incorporation assays and in situ hybridizations for *Maf*, *Prox1* and the Cdk inhibitor, *p57^{KIP2}* all showed that the site of fiber cell induction moved over time to the posterior pole of the lens in the FR3 mice. Crystallin synthesis was not significantly decreased in FR3 mice, suggesting that lens differentiation, once initiated, proceeded normally. MAP kinase phosphorylation was found to be diminished in FR3 mice. The lens epithelial cells of FR3 mice still retained their ability to respond to FGF stimulation as they could be induced to initiate their differentiation program by ectopic overexpression of FGF8. Based on these results, we propose that the secreted self-dimerizing FR3 is inhibiting fiber cell initiation by binding to and sequestering the endogenous inductive signals present in the vitreous humor. As FGFR3 binds to FGFs, we predict that the inductive signal is an FGF or an FGF-like protein. Although there is evidence that FGF receptors can be activated by cell adhesion molecules (CAMs) such as E-cadherin, NCAM or L1 (Doherty and Walsh, 1996), there is no evidence that such proteins play a role in lens fiber cell induction. Lens transplant experiments have shown that the inductive signal can diffuse from the vitreous through the intact basement membrane of the lens capsule (reviewed in DeHaan and Ursprung, 1965), implying that the signal is a secreted protein. Therefore, we have no reason to believe that the secreted form of FGFR3 is blocking fiber cell induction by binding to a CAM.

Candidate FGFs likely to be involved in lens differentiation

FGF family members that might be involved in lens differentiation, based on their expression pattern, include FGF1, 2, 3, 5, 11, 12, 13 or 15. FGF1 and FGF2 are expressed in the lens (de Iongh and McAvoy, 1993; Lovicu et al., 1997), FGF2, 3, 5, 11, 12, 13 and 15 are expressed in the retina (Wilkinson et al., 1989; de Iongh and McAvoy, 1993; Kitaoka et al., 1994; Smallwood et al., 1996; Lovicu et al., 1997; McWhirter et al., 1997). FGF1 and FGF2 are not likely to be involved in lens differentiation. Targeted deletions of FGF1 and FGF2 do not result in ocular abnormalities (Dono et al., 1998; Ortega et al., 1998), and FGF1 and FGF2 double knockouts have also not been reported to have eye defects

Fig. 8. Lens epithelial cells in FR3 transgenic mice are competent to respond to FGF stimulation. Eyes of newborn or P14 mice from matings of FR3 (OVE1548A) transgenic mice to CPV2-FGF8 (OVE846) or CPV2-FGF7 (OVE842) transgenic mice were sectioned and stained with hematoxylin and eosin. At P1, lenses of FR3 transgenic mice show epithelial cells around nearly the entire circumference of the lens (A). Lens epithelial cells of FGF8 transgenic mice show premature elongation and differentiation into fiber cells (B; Lovicu and Overbeek, 1998). Lens epithelial cells of mice that are transgenic for both FR3 and FGF8 are still induced to differentiate (C). Note that FR3 appears to partially inhibit the epithelial cell elongation induced by FGF8 (compare B with C). P14 lenses from mice transgenic for both FR3 and FGF7 were indistinguishable from the FR3 transgenic lenses (compare F with D) with epithelial cells encircling the lens. The red arrowheads in E,F mark the lacrimal gland-like structures that are induced in the corneas by FGF7 in the presence (F) or in the absence (E) of FR3. le, lens epithelium, lf, lens fibers. Scale bar: 200 μ m in A,C-F; 100 μ m in B.

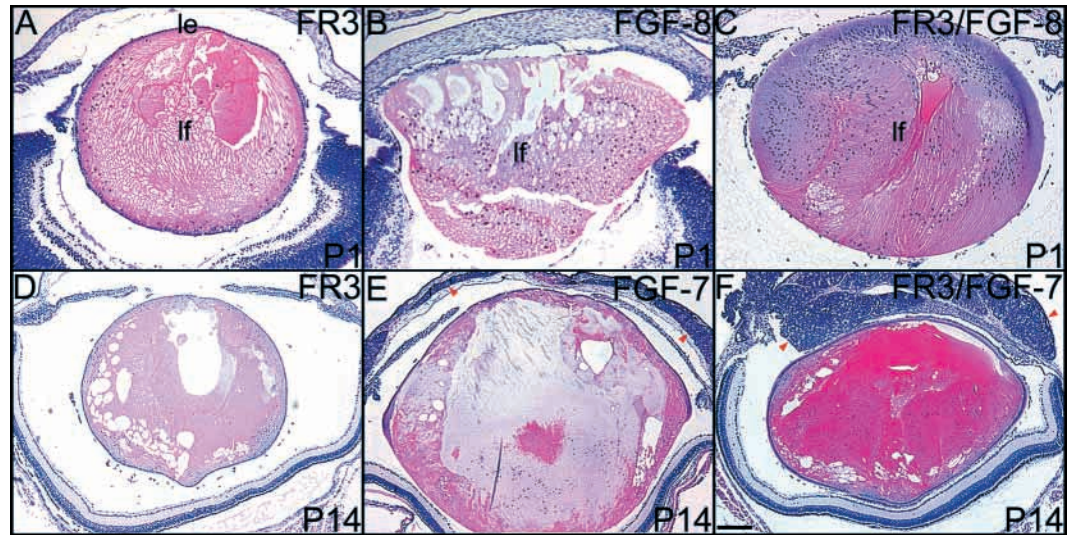

(Miller et al., 2000). Similarly, neither FGF3 nor FGF5 is likely to be the endogenous lens differentiation signal. Although expression of FGF3 is seen in the neuroretina during lens differentiation, the expression is transient and a targeted deletion of FGF3 results in mice with no apparent ocular abnormalities (Mansour et al., 1993). FGF5 mutant mice also do not have any eye defects (Hebert et al., 1994). FGF11, FGF12 and FGF13 are expected not to be secreted proteins as they lack a signal peptide (Smallwood et al., 1996). Strong expression of FGF15 is seen in the neuroretina during embryonic development but expression levels fall postnatally (V. G., unpublished). As FGF15 null mice die at E10.5, it is not clear at the present time if FGF15 is involved in lens differentiation (Tom Reh, personal communication). Since the effect of FR3 expression is most apparent postnatally, FGF15 may not be the relevant FR3 target. However, an alternative explanation is that during embryonic development, there may not be sufficient FR3 in the vitreous humor to block the actions of FGF15. Postnatally, when levels of FGF15 fall, there could be effective inhibition leading to the delay in initiation of fiber cell differentiation. Therefore, it is possible that the lens differentiation signal is either FGF15 or one of the more recently identified members of the FGF family.

Phosphorylation of Erk1 and Erk2 in FR3 mice

Erk1 and Erk2 phosphorylation levels were decreased in FR3 transgenic mice suggesting that initiation of lens fiber differentiation may be mediated, at least in part, through the Ras-Raf-MAP kinase pathway. However, it appears that activation of Erk1 and Erk2 may not be sufficient for induction of the fiber differentiation program as expression of an oncogenic version of Ras in the lens epithelial cells does not induce fiber cell formation (L. Reneker, V. G. and P. A. O., unpublished). It is possible that transient stimulation of MAP kinase is required to initiate fiber cell differentiation.

Alternatively, activation of MAP kinase may not be required for the fiber cell differentiation program.

Persistence of the hyaloid vasculature in FR3 mice

The hyaloid blood vessels around the lens normally begin to regress by P7, but they were found to persist in FR3 mice. This raises the question of whether the inhibition of lens differentiation is a consequence of persistence of the vasculature. This possibility seems unlikely given that the vasculature regresses at a later stage in FR3 mice, but the lens differentiation still remains blocked (data not shown). BrdU incorporation studies showed that the persistence of the vasculature was accompanied by proliferation of the endothelial cells. One possible explanation for the vascular persistence may be that the macrophages responsible for cell death and remodeling of blood vessels in the eye (Lang and Bishop, 1993) may not be present in the FR3 mice. Survival of the macrophages may require FGF signaling and the presence of the FR3 protein in the vitreous may abolish this signaling activity. Another interpretation is that there could be a signal made by the lens fiber cells that induces regression of the vasculature during development and this signal is no longer produced at normal levels in the FR3 mice.

Is FGFR1 required for lens differentiation?

Previously, it has been reported that lens fiber-specific expression of membrane-bound truncated versions of FGFR1 (lacking the cytoplasmic domain) inhibited fiber cell maturation but not initiation of fiber cell differentiation (Chow et al., 1995; Robinson et al., 1995a; Stolen and Griep, 2000). These earlier results contrast with the results of our study where expression of a secreted version of FGFR1 did not affect lens differentiation. One possible explanation for the apparent discrepancy is that the transgenic FR1 protein may not be functionally active. Although secreted FR1 has been shown to be biologically active in *in vitro* culture assays (Ye et al., 1998),

it remains possible that it is not active in vivo in the eye. Another possibility is that the truncated FGFR1 used previously may inhibit the functions of other FGF receptors (such as FGFR2) in the lens, perhaps by heterodimer formation. As TUNEL-positive nuclei were observed in the truncated FGFR1 lenses but not in the secreted FR1 lenses, it is also conceivable that the truncated FGFR1 could be toxic to the fiber cells.

Models for FR3 inhibition

The movement of the fiber cell initiation region to the posterior pole of the lens in the FR3 mice raises the following question: does FR3 inhibit the lens differentiation signal or does it inhibit an anti-proliferation signal, or both? Although it is possible that there are two distinct signals, one to induce cell cycle exit and another to initiate the differentiation program, the results from previous studies suggest that FGFs can perform both these functions (McAvoy and Chamberlain, 1989; Robinson et al., 1995b; Lovicu and Overbeek, 1998; Robinson et al., 1998; Lovicu and McAvoy, 1999). FGFs can induce the expression of *p57^{KIP2}*, which leads to cell cycle arrest (Lovicu and McAvoy, 1999). In addition, overexpression of FGFs can induce differentiation of fiber cells both in vivo and in vitro (McAvoy and Chamberlain, 1989; Robinson et al., 1995b; Robinson et al., 1998). Based on these results, we postulate that FR3 binds to an endogenous FGF-like protein that is otherwise able to induce cell cycle arrest and initiate fiber cell differentiation. The FR3 mice show no evidence of enhanced epithelial cell proliferation (Table 1). In fact, there is a reduced number and percentage of BrdU-positive epithelial cells, suggesting that FR3 may be partially inhibiting a proliferative factor. This observation fits with the previous experiments (Chamberlain and McAvoy, 1989) showing that lower levels of FGF can stimulate epithelial cell proliferation.

Other questions still need to be addressed: why does expression of FR3 inhibit fiber cell initiation more effectively postnatally than prenatally? And why does initiation of differentiation still occur at the posterior pole of the lens? There are at least two possible explanations. One possibility is that there are two distinct signals, one (a posterior signal) to initiate lens differentiation during embryonic development and another (a lateral signal) to initiate lens differentiation postnatally. It is possible that the postnatal (lateral) signal is a specific FGF that is blocked more effectively by FR3. An alternative explanation is that the levels of FR3 protein are not high enough to block FGF signaling prenatally, but postnatally there is sufficient FR3 protein accumulation in the vitreous to block FGF action.

The results of our study support the FGF-gradient hypothesis (McAvoy and Chamberlain, 1989). It proposes the existence of an anterior-posterior gradient of FGF activity in the ocular media surrounding the lens: higher FGF activity in the vitreous humor would induce differentiation of fiber cells in the posterior portion of the lens and lower FGF activity in the aqueous humor at the transition zone would stimulate proliferation of the epithelial cells. Our study provides experimental evidence that the endogenous fiber cell induction signal is in fact an FGF or FGF-like factor. Identification of the factor bound by FR3 is clearly an important goal for future research.

We thank Dr Arnon Rosenthal for providing the mouse FR1 and

FR3 cDNA clones, Dr Guillermo Oliver for providing the Prox1 cDNA, Dr Steve Elledge for providing the *p57^{KIP2}* cDNA, Drs Brian Ring and Greg Barsh for the Maf cDNA clone, and Paige Adams for providing hippocampal cell lysates. We are grateful to Gabriele Schuster for performing the microinjections, Long Vien for assistance in animal husbandry, Barbara Harris for help in histological analyses and Dr Fred A. Pereira for insightful comments and discussion. We also thank Drs Jeffrey Rosen and Randy Johnson for critical reading of the manuscript. This work was supported by NIH grants EY-10448 and EY-10803 (P. A. O.).

REFERENCES

- Arman, E., Haffner-Krausz, R., Chen, Y., Heath, J. K. and Lonai, P. (1998). Targeted disruption of fibroblast growth factor (FGF) receptor 2 suggests a role for FGF signaling in pregastrulation mammalian development. *Proc. Natl. Acad. Sci. USA* **95**, 5082-5087.
- Chow, R. L., Roux, G. D., Roghani, M., Palmer, M. A., Rifkin, D. B., Moscatelli, D. A. and Lang, R. A. (1995). FGF suppresses apoptosis and induces differentiation of fibre cells in the mouse lens. *Development* **121**, 4383-4393.
- de Iongh, R. and McAvoy, J. W. (1993). Spatio-temporal distribution of acidic and basic FGF indicates a role for FGF in rat lens morphogenesis. *Dev. Dyn.* **198**, 190-202.
- de Iongh, R. U., Lovicu, F. J., Hanneken, A., Baird, A. and McAvoy, J. W. (1996). FGF receptor-1 (*flg*) expression is correlated with fibre differentiation during rat lens morphogenesis and growth. *Dev. Dyn.* **206**, 412-426.
- de Iongh, R. U., Lovicu, F. J., Chamberlain, C. G. and McAvoy, J. W. (1997). Differential expression of fibroblast growth factor receptors during rat lens morphogenesis and growth. *Invest. Ophthalmol. Vis. Sci.* **38**, 1688-1699.
- DeHaan, R. L. and Ursprung, H. (1965). *Organogenesis*. New York: Holt Rinehart and Winston.
- Deng, C. X., Wynshaw-Boris, A., Shen, M. M., Daugherty, C., Ornitz, D. M. and Leder, P. (1994). Murine FGFR-1 is required for early postimplantation growth and axial organization. *Genes Dev.* **8**, 3045-3057.
- Doherty, P. and Walsh, F. S. (1996). CAM-FGF receptor interactions: A model for axonal growth. *Mol. Cell Neurosci.* **8**, 99-111.
- Dono, R., Texido, G., Dussel, R., Ehmke, H. and Zeller, R. (1998). Impaired cerebral cortex development and blood pressure regulation in FGF-2-deficient mice. *EMBO J.* **17**, 4213-4225.
- Feldman, B., Poueymirou, W., Papaioannou, V. E., DeChiara, T. M. and Goldfarb, M. (1995). Requirement of FGF-4 for postimplantation mouse development. *Science* **267**, 246-249.
- Floss, T., Arnold, H. H. and Braun, T. (1997). A role for FGF-6 in skeletal muscle regeneration. *Genes Dev.* **11**, 2040-2051.
- Govindarajan, V., Ito, M., Makarenkova, H. P., Lang, R. A. and Overbeek, P. A. (2000). Endogenous and ectopic gland induction by FGF-10. *Dev. Biol.* **225**, 188-200.
- Guo, L., Degenstein, L. and Fuchs, E. (1996). Keratinocyte growth factor is required for hair development but not for wound healing. *Genes Dev.* **10**, 165-175.
- Hebert, J. M., Rosenquist, T., Gotz, J. and Martin, G. R. (1994). FGF5 as a regulator of the hair growth cycle: evidence from targeted and spontaneous mutations. *Cell* **78**, 1017-1025.
- Kitaoka, T., Aotaki-Keen, A. E. and Hjelmeland, L. M. (1994). Distribution of FGF-5 in the rhesus macaque retina. *Invest. Ophthalmol. Vis. Sci.* **35**, 3189-3198.
- Lang, R. A. and Bishop, J. M. (1993). Macrophages are required for cell death and tissue remodeling in the developing mouse eye. *Cell* **74**, 453-462.
- Lovicu, F. J., de Iongh, R. U. and McAvoy, J. W. (1997). Expression of FGF-1 and FGF-2 mRNA during lens morphogenesis, differentiation and growth. *Curr. Eye Res.* **16**, 222-230.
- Lovicu, F. J. and Overbeek, P. A. (1998). Overlapping effects of different members of the FGF family on lens fiber differentiation in transgenic mice. *Development* **125**, 3365-3377.
- Lovicu, F. J., Kao, W. W. and Overbeek, P. A. (1999). Ectopic gland induction by lens-specific expression of keratinocyte growth factor (FGF-7) in transgenic mice. *Mech. Dev.* **88**, 43-53.

- Lovicu, F. J. and McAvoy, J. W.** (1999). Spatial and temporal expression of p57(KIP2) during murine lens development. *Mech. Dev.* **86**, 165-169.
- Mansour, S. L., Goddard, J. M. and Capecchi, M. R.** (1993). Mice homozygous for a targeted disruption of the proto-oncogene int-2 have developmental defects in the tail and inner ear. *Development* **117**, 13-28.
- Martin, G. R.** (1998). The roles of FGFs in the early development of vertebrate limbs. *Genes Dev.* **12**, 1571-1586.
- McAvoy, J. W. and Chamberlain, C. G.** (1989). Fibroblast growth factor (FGF) induces different responses in lens epithelial cells depending on its concentration. *Development* **107**, 221-228.
- McAvoy, J. W., Chamberlain, C. G., de Jongh, R. U., Hales, A. M. and Lovicu, F. J.** (1999). Lens development. *Eye* **13**, 425-437.
- McWhirter, J. R., Goulding, M., Weiner, J. A., Chun, J. and Murre, C.** (1997). A novel fibroblast growth factor gene expressed in the developing nervous system is a downstream target of the chimeric homeodomain oncoprotein E2A-Pbx1. *Development* **124**, 3221-3232.
- Meyers, E. N., Lewandoski, M. and Martin, G. R.** (1998). An Fgf8 mutant allelic series generated by Cre- and Flp-mediated recombination. *Nat. Genet.* **18**, 136-141.
- Miller, D. L., Ortega, S., Bashayan, O., Basch, R. and Basilico, C.** (2000). Compensation by fibroblast growth factor 1 (FGF1) does not account for the mild phenotypic defects observed in FGF2 null mice. *Mol. Cell Biol.* **20**, 2260-2268.
- Min, H., Danilenko, D. M., Scully, S. A., Bolon, B., Ring, B. D., Tarpley, J. E., DeRose, M. and Simonet, W. S.** (1998). Fgf-10 is required for both limb and lung development and exhibits striking functional similarity to *Drosophila* branchless. *Genes Dev.* **12**, 3156-3161.
- Nishiguchi, S., Wood, H., Kondoh, H., Lovell-Badge, R. and Episkopou, V.** (1998). Sox1 directly regulates the gamma-crystallin genes and is essential for lens development in mice. *Genes Dev.* **12**, 776-781.
- Ornitz, D. M., Xu, J., Colvin, J. S., McEwen, D. G., MacArthur, C. A., Coulier, F., Gao, G. and Goldfarb, M.** (1996). Receptor specificity of the fibroblast growth factor family. *J. Biol. Chem.* **271**, 15292-15297.
- Ortega, S., Ittmann, M., Tsang, S. H., Ehrlich, M. and Basilico, C.** (1998). Neuronal defects and delayed wound healing in mice lacking fibroblast growth factor 2. *Proc. Natl. Acad. Sci. USA* **95**, 5672-5677.
- Overbeek, P. A., Chepelinsky, A. B., Khillan, J. S., Piatigorsky, J. and Westphal, H.** (1985). Lens-specific expression and developmental regulation of the bacterial chloramphenicol acetyltransferase gene driven by the murine alpha A-crystallin promoter in transgenic mice. *Proc. Natl. Acad. Sci. USA* **82**, 7815-9.
- Reker, L. W., Silversides, D. W., Patel, K. and Overbeek, P. A.** (1995). TGF alpha can act as a chemoattractant to periostic mesenchymal cells in developing mouse eyes. *Development* **121**, 1669-1680.
- Ring, B. Z., Cordes, S. P., Overbeek, P. A. and Barsh, G. S.** (2000). Regulation of mouse lens fiber cell development and differentiation by the Maf gene. *Development* **127**, 307-317.
- Robinson, M. L., MacMillan-Crow, L. A., Thompson, J. A. and Overbeek, P. A.** (1995a). Expression of a truncated FGF receptor results in defective lens development in transgenic mice. *Development* **121**, 3959-3967.
- Robinson, M. L., Overbeek, P. A., Verran, D. J., Grizzle, W. E., Stockard, C. R., Friesel, R., Maciag, T. and Thompson, J. A.** (1995b). Extracellular FGF-1 acts as a lens differentiation factor in transgenic mice. *Development* **121**, 505-514.
- Robinson, M. L., Ohtaka-Maruyama, C., Chan, C. C., Jamieson, S., Dickson, C., Overbeek, P. A. and Chepelinsky, A. B.** (1998). Disregulation of ocular morphogenesis by lens-specific expression of FGF-3/int-2 in transgenic mice. *Dev. Biol.* **198**, 13-31.
- Sekine, K., Ohuchi, H., Fujiwara, M., Yamasaki, M., Yoshizawa, T., Sato, T., Yagishita, N., Matsui, D., Koga, Y., Itoh, N. et al.** (1999). Fgf10 is essential for limb and lung formation. *Nat. Genet.* **21**, 138-141.
- Smallwood, P. M., Munoz-Sanjuan, I., Tong, P., Macke, J. P., Hendry, S. H., Gilbert, D. J., Copeland, N. G., Jenkins, N. A. and Nathans, J.** (1996). Fibroblast growth factor (FGF) homologous factors: new members of the FGF family implicated in nervous system development. *Proc. Natl. Acad. Sci. USA* **93**, 9850-9857.
- Stolen, C. M. and Griep, A. E.** (2000). Disruption of lens fiber cell differentiation and survival at multiple stages by region-specific expression of truncated FGF receptors. *Dev. Biol.* **217**, 205-220.
- Szebenyi, G. and Fallon, J. F.** (1999). Fibroblast growth factors as multifunctional signaling factors. *Int. Rev. Cytol.* **185**, 45-106.
- Wigle, J. T., Chowdhury, K., Gruss, P. and Oliver, G.** (1999). Prox1 function is crucial for mouse lens-fibre elongation. *Nat. Genet.* **21**, 318-322.
- Wilkinson, D. G., Bhatt, S. and McMahon, A. P.** (1989). Expression pattern of the FGF-related proto-oncogene int-2 suggests multiple roles in fetal development. *Development* **105**, 131-136.
- Xu, X., Weinstein, M., Li, C., Naski, M., Cohen, R. I., Ornitz, D. M., Leder, P. and Deng, C.** (1998). Fibroblast growth factor receptor 2 (FGFR2)-mediated reciprocal regulation loop between FGF8 and FGF10 is essential for limb induction. *Development* **125**, 753-765.
- Yamaguchi, T. P., Harpal, K., Henkemeyer, M. and Rossant, J.** (1994). Fgf-1 is required for embryonic growth and mesodermal patterning during mouse gastrulation. *Genes Dev.* **8**, 3032-3044.
- Ye, W., Shimamura, K., Rubenstein, J. L., Hynes, M. A. and Rosenthal, A.** (1998). FGF and Shh signals control dopaminergic and serotonergic cell fate in the anterior neural plate. *Cell* **93**, 755-766.
- Zhang, P., Wong, C., DePinho, R. A., Harper, J. W. and Elledge, S. J.** (1998). Cooperation between the Cdk inhibitors p27(KIP1) and p57(KIP2) in the control of tissue growth and development. *Genes Dev.* **12**, 3162-3167.