

## RESEARCH ARTICLE

# Dolphin blubber/axial muscle shear: implications for rigid transdermal intramuscular tracking tag trauma in whales

Michael J. Moore<sup>1,\*</sup> and Alexandre N. Zerbini<sup>2,3</sup>

## ABSTRACT

Whale tracking tags often penetrate semi-rigid blubber, with intramuscular sharp tips and toggling barbs under the subdermal sheath to reduce premature shedding. Tag sites can show persistent regional swellings or depressions. Fibroelastic blubber grips a tag, so if muscle shears relative to blubber during locomotion, the tag tip could cavitate the muscle within overall shearing distance. We modeled shearing of blubber relative to muscle, within the dorsal-ventral peduncular movement range of four common dolphin (*Delphinus delphis*) cadavers (mean length 186 cm). The net change in angle and hence tip distance moved was calculated with dorsal and ventral flexion, and compared between 1.5 mm diameter needles inserted into blubber only and through blubber into muscle. The greatest shearing value was 3.6 cm, and shearing was most pronounced in the areas ventral and caudal to the dorsal fin. Scaled dummy tags were also inserted and the animal cyclically flexed dorsally and ventrally for 18 h. Tag sites were dissected and cavities around the tag tips documented. If this shearing is comparable in large whales, depressions and regional swellings observed with intramuscular tracking tags are likely the result of tissue loss and repair, respectively. Placing tags para-sagittally anterior to the dorsal fin would cause the least trauma, but pain from such tags remains a concern.

**KEY WORDS:** *Delphinus*, Telemetry, Tracking, Implantable, Mysticete, Odontocete

## INTRODUCTION

Tagging of large cetaceans to track their migratory movements has been undertaken since the 1920s, first on a significant geographical scale by Sir Sydney Harmer and colleagues in Great Britain (Brown, 1978) with non-electronic tags and, more recently, by various other scientists using electronic radio and satellite tags (e.g. Andrews et al., 2008; Mate et al., 2007; Watkins, 1981; Zerbini et al., 2006). Early efforts involved individually identifiable ‘Discovery marks’ being fired into a whale that would be recovered when the whale was later killed. Early Discovery marks (Brown, 1978) were limited to penetration of the blubber, but their attachment was short-lived in that, as described by Brown, ‘blubber suppurates readily and... whales can rid themselves of deep rooted external parasites’. Discovery marks were later designed to fully

embed in the skeletal muscle, be recovered during processing after harvest and infer movement from tagging to harvest sites. Subsequently, efforts were made to develop tags that could be tracked using radio and, more recently, satellites. The need to telemeter position data required an antenna that protruded into the air when the animal surfaced, but there was also the need for a tag body attachment that was durable for many months. Thus radio and satellite tags were designed (Mate et al., 2007; Watkins, 1981) to have a protruding antenna but low drag, so they stabbed through the blubber into the muscle, with a sharp tip and barbs or flaps designed to open once implanted, to enable the barbs or flaps to fetch up on the fibrous subdermal sheath, reducing the tag’s tendency to be shed by the cyclical movements of the swimming cetacean and the host’s foreign body reaction.

Long-term photo identification studies of right, humpback, grey and blue whales have provided some information on the appearance of tracking tag implantation sites, both during the period of tag retention and following shedding of all or part of the tag (Best et al., 2015; Best and Mate, 2007; Gendron et al., 2015; Mate et al., 2007; Robbins et al., 2013). Associated lesions have included persistent regional swellings and, commonly, depressions in the skin and blubber at the tag rejection site (Gendron et al., 2015; Robbins et al., 2013). There has been little direct study of this important topic, given the challenge of longitudinal studies of sufficient duration and scope.

An important aspect of any rigid implant that penetrates the blubber into the underlying muscle is the question of the degree to which the blubber and muscle glide past one another with the cyclical movement associated with a cetacean swimming. Inherently, such a movement seems very likely, given the relative lack of structures that cross the blubber–muscle interface. Indirect evidence for such movement was derived from a major bend in an intramuscular injection needle recovered at necropsy 10 days after a sedation-assisted fishing gear disentanglement of a North Atlantic right whale (*Eubalaena glacialis*). This bend was at the blubber–muscle interface, overlying a cavity carved by the needle tip in the underlying muscle (Moore et al., 2013). The vertebral muscle masses are enclosed in an often multilayered subdermal fibrous sheath, overlain by variable amounts of semiliquid fat, beneath the more organized fibroelastic structural blubber, that has been best described in the bottlenose dolphin (Pabst, 1990), but appears comparable in large odontocetes and mysticetes that are tracked with implantable tracking tags. Thus the structural blubber may have significant freedom to slide over the muscle as the musculoskeletal system flexes during locomotion. The degree of this freedom may vary in different parts of the body. Most rigid tracking tags penetrate the blubber into the muscle. The blubber is less deformable than the underlying muscle. Thus for tags fixated in the more rigid fibroelastic structural blubber that also penetrate into the dorsal muscle mass, the degree to which the tag moves within the muscle into which it is implanted is an important question. Knowledge of

<sup>1</sup>Woods Hole Oceanographic Institution, Woods Hole, MA 02543, USA. <sup>2</sup>Cascadia Research Collective, 218 1/2 W 4th Ave, Olympia, WA 98501, USA. <sup>3</sup>Marine Mammal Laboratory, Alaska Fisheries Science Center, 7600 Sand Point Way NE, Seattle, WA 98115-649, USA.

\*Author for correspondence (mmoore@whoi.edu)

 M.J.M., 0000-0003-3074-6631

this may yield a better understanding of the potential for chronic trauma induced by such devices and can inform development of new tag designs.

In this study, we measured the extent of the mobility of the blubber relative to the muscle during the locomotory cycle using a simple needle indicator system, and modeled the potential trauma of rigid tags that penetrate both muscle and blubber, with an experimental oscillating dolphin system. The specific questions we addressed were the following. To what degree does the blubber slide over the muscle in cetaceans in different body areas accessible for tag application? If such movement is measurable, does it have the potential to result in muscular cavitation? If significant, does this have implications for optimal location and depth of penetration of tracking tags? Do the findings help explain observations of regional swellings and or depressions in large whales carrying intramuscular tracking tags? These concerns also raise questions about the potential for pain during tag carriage, and consequent changes in the behavior of the tracked animal.

## MATERIALS AND METHODS

### Materials

Freshly dead stranded short-beaked common dolphins (*Delphinus delphis* Linnaeus 1758) were transported to a 4°C chiller. Dolphins entered rigor mortis a few hours after death. Experiments were undertaken 24–48 h post mortem once rigor had subsided.

Dolphin cadavers were collected by the International Fund for Animal Welfare Marine Mammal Rescue Research group, under a NOAA Stranding Agreement, and received by M.J.M. with permission in a letter from the Greater Atlantic Regional Fisheries Office.

### Shear experiment

Needles (17 gauge, 1.5 mm diameter) were inserted on the dorsal midline and dorsolateral aspect of a dolphin, at stations that are exposed to the air during normal cetacean swimming, and are thus potential targets for tag implantation (Robbins et al., 2013), as illustrated in Fig. 1. Needles were inserted on the left side of each animal. Needle diameter was selected such that the needles would be as atraumatic as possible, but at the same time rigid enough to avoid bending during the expected relative shearing movements. Actual tag trauma modeling was addressed with the dummy tags below.



**Fig. 1. Location of needle and tag insertions in dolphin cadaver blubber/muscle shearing model.** Stations were labeled A through I. Station A is in the dorsal midline anterior to the dorsal fin (arrow). Stations B, D, F and H were the upper lateral line as shown in the figure, and stations C, E, G and I the lower lateral line. In this image, the scaled model tags are inserted prior to oscillation as described in the Materials and methods.

Blubber thickness of common dolphin specimens, as measured after the following experiments, ranged from 11 to 19 mm (Table 1). The needles were inserted in pairs or triplets, with one 9-cm needle penetrating the blubber only, 1 cm from the skin surface, a 12-cm needle through the blubber into the muscle, 4 cm below the skin surface, and in all but one of the cases a third 10-cm needle 2 cm below the skin surface through the blubber into the muscle just below the subdermal sheath (Fig. 2). All needles protruded 8 cm above the skin surface. Using a hemostat to grip the needle, they were inserted singly to form transverse groups at each station with 4 mm spacing within each group. Needles were marked to achieve desired depth of penetration. The resistance to penetration, and hence depth, of the subdermal sheath could be readily felt. The angle of penetration, with 0 deg being towards the head, parallel to a tangent to the sagittal plane of the skin surface, was then measured for each needle using a protractor, with the animal in the relaxed, dorsal flexed and ventral flexed positions (Fig. 2). Dorsal and ventral flexion was maintained with 3 mm Dyneema (New England Ropes, Fall River, MA, USA) braided lines pulled taut between holes cut in each tail fluke lobe and the dorsal fin, for dorsal flexion, and the tail flukes and the flippers for ventral flexion. The amount of flexion was determined by the compliance of the specimen to flex given approximately 20 kg load on a two to one purchase on each of the two lines, using a trucker's hitch. The resulting angles of dorsal and ventral flexion, as measured on lateral photographs of the flexed specimens, between the lateral midline anterior to the dorsal fin and the midline of the area underlain by the caudal vertebrae, are shown in Table 1. The straight distance between the dorsal and ventral flexed peduncle location is also shown in Table 1.

### Shear data analysis

The change in angle between each of the 2 and 4 cm depth intramuscular needles and the blubber-only needle at each station was then calculated between relaxed and dorsal flexion, and relaxed and ventral flexion as illustrated in Fig. 3. Total potential shear was then calculated as the difference between dorsal and ventral shear distance for each station at each blubber depth. These values were then normalized to a generic common dolphin total body length of 200 cm using body lengths given in Table 1. Microsoft Excel formulae for and results of these calculations are shown in Table S1.

### Oscillating tagged cetacean model

To investigate the potential for tag trauma following repetitive swimming movements by cetaceans, dolphin cadavers were used as a model system. An approximate linear scaling factor of 1/7th was derived from a generic humpback whale of length 14 m and a dolphin of 2 m. Nine scaled, rigid, transdermal, intramuscular tags were modelled after a modified (rigid) version of the articulated anchor tag design developed by Gales et al. (2009) as described in Robbins et al. (2013). The actual whale tags are 300 mm in length and 24 mm in diameter and the scaled tags were 40 mm in length and 5 mm in diameter (Fig. 4). The depth of penetration of each tag therefore equaled the depth of the deeper (4 cm) intramuscular needle series described above. The model tags replicated the cutting tips and spring-loaded hinged flaps of the whale-sized instrument, but the scaled dimensions precluded including any retaining petals. The model shafts were threaded with a nut and washer at the skin surface to achieve a standard penetration depth. The tags were manually inserted, using locking pliers, into the blubber and muscle at the stations shown in Fig. 1. The tags were inserted on the right side of the animal, perpendicular to the epidermal surface. Gentle

**Table 1. Common dolphin cadaver measurements with experiments undertaken showing for each case: ID, length, sex, blubber thickness, mass, needle depth used in each experiment, degrees of body flexion achieved, resultant peduncle travel and whether the tag model experiment was undertaken**

ID	Case	Total length (cm)	Sex	Dorsal/ventral/lateral blubber thickness (mm)	Mass (kg)	Needle experiment		Needle experiment flexion (deg)			Peduncle travel needle (cm)	Tag model
						4 cm depth	2 cm depth	Dorsal	Ventral	Total		
IFAW14-145Dd*	1	225	M	13/11/12	107.8	Y	Y	73	106	179	52	Y
IFAW15-031Dd	2	169.5	F	18/17/18	54.6	Y	N	53	67	120	52	Y
IFAW15-196Dd	3	191	F	16/19/18	72.4	Y	Y	44	103	147	64	N
IFAW15-224Dd	4	167.5	F	n.a.	52.5	Y	Y	44	16	60	44	N
IFAW14-150Dd	5	179	F	14/13/12	54.6	N	N	n.a.	n.a.	n.a.	n.a.	Y

\*Frozen and thawed before experiment.  
n.a., data not available.

retraction confirmed that the flaps had opened and were engaged in the tissue.

A pneumatic cylinder assembly was attached to an overhead rail, to suspend the dolphin as well as oscillate the tail as shown in Fig. 5. A schematic of the pneumatic oscillator control system is shown in Fig. 6. The pneumatic components were acquired from Air Incorporated (Franklin, MA, USA). The 7.6 cm diameter cylinder operated on 550 kPa compressed air and was capable of providing a stroke of up to 1.2 m with a force of 240 kg. The distance of the stroke was controlled by adjusting the separation between the two limit switch pilot valves. When these valves were actuated by piston contact, they reversed the direction of air flow through the four-way double air valve and thus reversed the piston's direction. Thus, while operating, the piston would continually travel back and forth between the limit switch positions and raise and lower the dolphin tail. The speed of the piston (i.e. oscillation rate) was controlled using a flow speed controller.

The dolphin cadavers were held in a tank of water at a temperature of 4°C within a 4°C chiller. The tank was 100 cm wide, 250 cm long with 110 cm depth of water. The dolphin rostrum was suspended at the water surface between an overhead line and a line down to a 16 kg weight resting on the tank bottom (Fig. 5). Lines from the overhead rail were attached to each axilla and adjusted such that the dorsal fin was vertically oriented and the body restrained from rotating along its body axis. A sling was loosely suspended under the animal at the dorsal fin to help the body keep position in the tank. None of these restraints interfered with the implanted tags. The

overhead reciprocating compressed air piston was attached to a line that ran over a pulley to change the line's direction by 90 deg, and hence vertically down to the peduncle. An 81 kg weight was suspended from the peduncle. The line from the pulley and that down to the weight were attached to an 18 mm braided line tied around the peduncle to minimize chafe. The peduncle was thus moved to mimic body swimming movements, albeit with a lower frequency than in a live animal, with a period of 21 s. The peduncle height was adjusted to give approximately equivalent dorsal and ventral flexion. The distance from full dorsal to full ventral flexion of the peduncle was 94 cm. The oscillator was left to run for 18 h (3240 oscillations). At the end of each experiment, each tag site was excised in a 6×6×6 cm block of skin, blubber and muscle. Using a scalpel, a parasagittal cut was made 2 mm lateral to the shaft of the model tag through the skin, blubber and muscle. Then using fine pointed scissors, a coronal incision was made down to the tag shaft and flaps. The extent to which the flaps had deployed was recorded, and any flap detachment and the orientation of the tip were noted. The height and width of any cavity present around the tag flaps and shaft was measured.

## RESULTS

### Shearing experiment

Experiments were undertaken with four cadavers (Table 1) where degrees of dorsal and ventral flexion and peduncle travel distance are shown. Needle angles measured and subsequent calculations, as described in the Materials and methods, are given in Table S1.

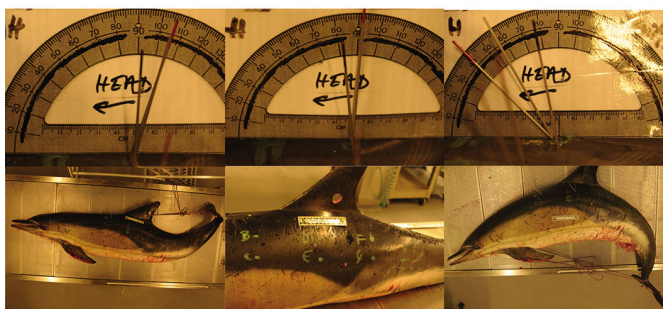

**Fig. 2. Examples of needle experiment trials showing dolphin blubber muscle shearing with dorsal and ventral flexion.** Left to right, both rows: dorsal flexed, straight and ventral flexed posture. Upper row: representative images of needle position (station H – upper station row, caudal to dorsal fin). Needle penetration depths with tip colors: 1 cm – black, blubber only; 2 cm – silver, shallow muscle; 4 cm – red, deeper muscle. Lower row: common dolphin cadaver in each position. Flexion dorsally moves the muscle craniad, and flexion ventrally moves the muscle caudad, relative to the blubber.

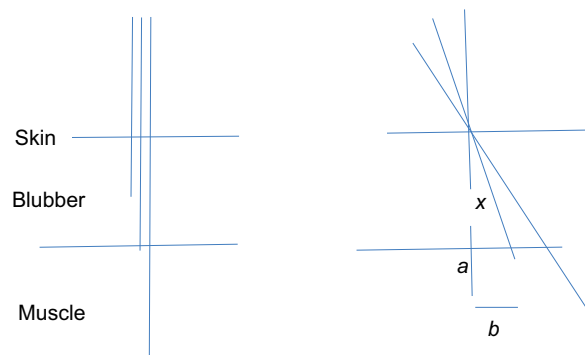

**Fig. 3. Calculation of needle shear from change in angle between each intramuscular needle and the blubber-only needle at each station between relaxed and dorsal or ventral flexion.** Each of those angles ( $x$ ) were converted to a net linear shear using the equation  $b=atanx$ , where  $a$  is the distance from skin surface to needle tip, and  $b$  is the linear distance traveled by the needle tip between relaxed and dorsal or ventral flexion.





**Fig. 4. Large whale tracking tag and 1/7th scaled dolphin dummy tag.** Inset shows dummy tag at a larger scale. Scales in cm.

Resulting total potential shear at each station location (Fig. 1) is shown for 2 and 4 cm penetration in Table 2. Shearing was greater with 4 cm than 2 cm needle penetration, not surprisingly given the nature of the geometry involved, and for both depths shearing was least in the dorsal mid line anterior to the dorsal fin, and greatest in the upper lateral row adjacent and caudal to the dorsal fin. There was substantial variation between animals in terms of magnitude and pattern of maximal shearing. Case 1 (IFAW14-145Dd), which had been frozen and thawed prior to the experiment, showed less shearing than the other three cases. Case 4 (IFAW15-224Dd) was resistant to flexion, but showed substantial shearing. This case was likely still coming out of rigor, given the small amount of flexion achieved. Thus the muscle fibers may have been stiffer and less pliable.

#### Oscillating tagged cetacean model

Nine model tags were inserted at the positions illustrated in Fig. 1. Thus the oscillation tag experiment mirrored the 4-cm depth needle penetration depth and location on each animal. After 18 h of simulated locomotion, each tag location was dissected as described. Resulting cavities were measured, as shown in Table 3. Cavity width ranged from 0 to 11 mm, with a distribution that somewhat paralleled the extent of shearing measured in the needle experiment, where maximal cavitation lateral and caudal to the dorsal fin was observed (Table 2). Representative cavities are illustrated in Fig. 7. In Fig. 7, station G of Case 5, the largest cavity observed in the experiment also showed detachment of a tag barb in the cavity.

Gross necropsy indicated that the animals were in good body condition.

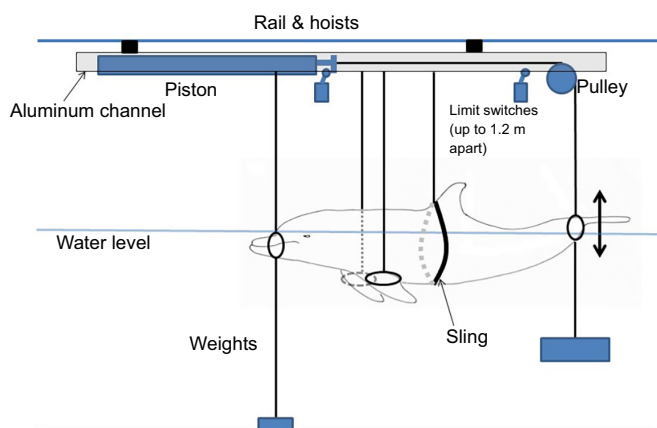
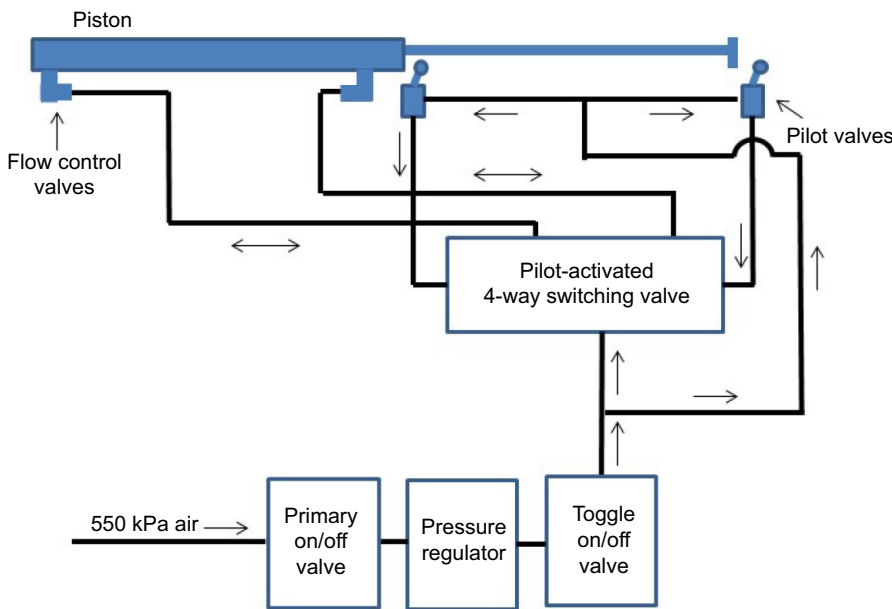

**Fig. 5. Experimental system for repeated oscillation of dolphin cadaver.** As described in the Materials and methods, a horizontally mounted compressed air piston rod moves the dolphin tail up and down via a rope passing over a pulley and attached to the peduncle. Weights hanging from the dolphin stabilize its movements. The dolphin is suspended in 4°C water (horizontal blue lines).

#### DISCUSSION

The fundamental value of this study is the observation that there can be marked shearing at the blubber–muscle interface of dolphins at least and likely all cetaceans. The applied value of this work is a deeper understanding of the biomechanics of transdermal, intramuscular tracking tags in cetaceans. When intramuscular tracking tags are deployed in wild cetaceans, the opportunity to evaluate the extent of the resultant muscular trauma is limited to inference from the external appearance of the tag wounds during any subsequent re-sighting. As far as we are aware, there are no published data describing the internal pathology of any intramuscular tagging wound. The present study was designed to evaluate and model the potential for shearing of the blubber over the muscle, and hence the risk of muscular trauma, as the tag shaft and cutting tip, while fixed in the blubber, could travel back and forth in the muscle. Issues to discuss include the relevance to a larger whale of modeling such trauma in a dolphin; the comparability of cadaver to live tissue; the extent of body movement as modeled compared with that in live animals swimming; the extent of shearing and tag trauma demonstrated; implications for where intramuscular tags should be deployed; the question of whether such tag trauma would be chronically painful; and consideration as to whether these findings warrant revisiting the possibility of engineering large whale tags that can remain attached for multiple months without penetrating into the muscle, or if muscle penetration is still necessary, how to develop devices that can accommodate shearing and minimize trauma.

The basic anatomical similarities between dolphins and the larger whales far exceed their differences. They are all based upon similar axial musculoskeletal systems, overlaid with cranial and anterior appendage adaptations variously evolved for different behavioral and foraging specializations. The anatomy of the blubber–muscle interface has best been described in the bottlenose dolphin. ‘The connective tissue fibers that form the subdermal sheath come from many sources: tendons of abdominal and axial muscles, ligamentous fibers, and connective tissue fibers from the blubber’ (Pabst, 1990). More particularly for this study, the arrangement of the skin, blubber and underlying muscle is very comparable between dolphins and large whales, with a semifluid fat and fibrous bilayered sheath interface between the blubber and the muscle (Moore et al., 2001). Details of this sheath system in dolphins and mysticetes are reviewed elsewhere (p. 276 in Miller et al., 2011). The bottlenose dolphin epaxial subdermal sheath is illustrated in Fig. 8 (Pabst, 1993). Given this anatomical similarity, it is reasonable to use the data from this study to predict the extent of shearing and risk of tag cavitation in large whales. Dolphin blubber–muscle shearing (Table 2) was shown to range between 0.1 and 6 cm, and tag oscillation to create cavities up to 1.5 cm (Table 3). However, a necessary caveat with the data in Table 3 is that the very act of dissecting the tag implantation site carried the risk of creating a small cavity around the tag, where perceived cavities were small. We considered repeating the oscillation experiment to allow for a computed tomography scan of the tag sites before dissection, but preliminary studies showed that the metallic tag induced major artefact in the scan, which would obscure any soft tissue cavitation. Using the same 2-m dolphin versus 14-m humpback whale scaling factor used to design the dolphin scale tag, one could hypothesize that there could be as much as 42 cm shearing and 10 cm cavitation in a 14-m humpback whale. This does not seem unreasonable given the apparent scale of depressions and swellings described in humpback whales with intramuscular tags (Robbins et al., 2013).



**Fig. 6. Control system for pneumatic dolphin oscillator.** The pneumatically controlled piston, as illustrated in Fig. 5, is powered by compressed air entering at the bottom left in the figure. It passes through the labeled components with air flow as indicated by arrows to enable a cyclical extension and retraction of the piston rod cyclically moving the dolphin tail as shown in Fig. 5. Direction of movement reverses whenever the piston rod end connects with one or the other pilot valves.

A fundamental question is the relevance of data from a dead animal to a live one. The needle experiment would seem to suggest that there is the potential for significant shearing between blubber and the underlying muscle. It is hard to conceive of how the shearing observed in the cadaver could occur, but yet would not occur in the same sites in a live animal to similar extents. This experiment does not replicate swimming, just the extent of body flexion that could occur during swimming and turning in a live animal. In contrast, the dummy tag experiment, with prolonged simulated swimming with implanted model tags, showed less cavitation than the needle experiment would have predicted. This is despite all the needle experiments resulting in a peduncle travel distance (Table 1) that was less than the 94-cm travel in the oscillating tag experiment. Significantly the shearing distances were less in Case 1, where the animal had been frozen and thawed prior to

the experiment. Thus the freeze/thaw artefact will have reduced the muscle fiber integrity, allowing the needle tip to be less constrained by the remaining muscle structure, reducing the overall shearing observed. There was no evidence on necropsy that the needle tips had lacerated the muscle fibers. This is not surprising in that flexion was slowly induced once, with the Dyneema purchases. That the extent of oscillating tag lacerations (Table 3) was less than the total shear distances (Table 2) may reflect some elasticity in the muscle fibers conforming to shear distortion to some degree. It is also possible that dead, flaccid, non-contractile muscle maybe less prone to laceration than the actively contracting and relaxing muscle fibers of a live swimming animal. But until tissue subject to such forces while in a live animal has been examined, it remains unclear as to whether the extent of the trauma observed in a live animal would be similar to that observed in a carcass.

**Table 2. Maximum shear of blubber over muscle 2 and 4 cm below the skin surface in common dolphin cadavers**

Depth	Plane	Station	Maximum shear (cm)					
			Case				Mean	s.d.
			1	3	2	4		
2 cm	Dorsal midline	A	0.2	0.1	–	2.0	0.2	0.0
		B	0.4	2.0	–	2.2	1.2	1.1
		D	1.1	3.0	–	2.2	2.0	1.4
		F	2.0	1.0	–	1.9	1.5	0.7
	Lower lateral	H	2.0	2.7	–	0.6	2.3	0.5
		C	0.3	0.1	–	2.0	0.2	0.1
		E	1.2	0.4	–	2.6	0.8	0.5
		G	1.8	0.3	–	0.7	1.0	1.0
		I	2.0	–0.1	–	1.3	1.0	1.5
4 cm	Dorsal midline	A	0.5	0.0	1.9	0.9	0.8	1.0
		B	1.8	3.3	3.4	2.4	2.8	0.9
		D	0.7	3.2	3.8	3.9	2.6	1.7
		F	2.6	5.0	3.3	2.2	3.6	1.3
	Lower lateral	H	2.7	5.6	2.4	1.7	3.6	1.8
		C	1.8	0.6	2.5	3.4	1.6	1.0
		E	4.1	0.7	1.2	2.7	2.0	1.8
		G	4.5	1.0	0.4	2.1	2.0	2.2
		I	6.3	0.6	0.4	1.9	2.4	3.3

Cases arranged left to right in decreasing amount of total flexion (see Table 1). –, no data.

The extent of the curvature we induced in these cadavers (Table 1) is comparable to that shown for bottlenose dolphin (*Tursiops truncatus*) cadavers (Etnier et al., 2008). In that study, juveniles showed a mean (±s.d.) maximal flexion of 40±17 deg dorsally and 48±10 deg ventrally. However, the angle of the tailstock to the x-axis mostly exceeds that of the maximum dorsal and ventral angles shown for live swimming bottlenose dolphins (Videler and Kamermans, 1985). Thus the values shown here for the needle and the tag oscillating experiments reflect a maximum.

**Table 3. Diameter of cavities carved by the intramuscular tag tip in three common dolphin cadavers oscillated for 18 h in simulated locomotion**

Plane	Station	Diameter (mm)				
		Case			Mean	s.d.
		1	2	5		
Dorsal midline	A	2	0	5	2.5	3
	B	2	3	5	3	2
	D	5	8	5	6	2
Lower lateral	F	8	8	5	7	2
	H	4	8	5	6	2
	C	4	0	11	5	6
	E	2	0	5	3.5	3
	G	4	8	15	9	6
	I	3	5	15	8	6

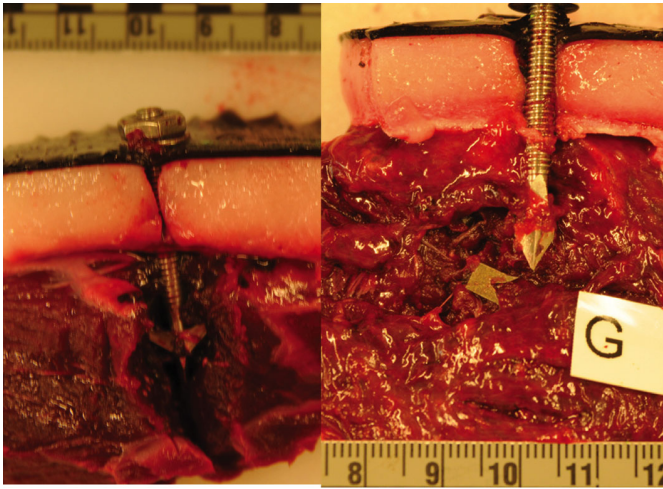

**Fig. 7. Dissection of dummy tag implant sites of individual IFAW14-150Dd.** Station A is on the left, G is on the right. Note that the stab wound in A is relatively limited to the location of the cutting point, whereas in G there is a cavity carved by the movement of the blubber relative to the muscle, with the tag held by the blubber. The mechanical shearing forces during the oscillations were sufficient to fracture the attachment point of one of the flaps, and to induce multiple tears in the muscle fibers. Scale markers in cm.

Despite our experiments representing the worst case for potential trauma given the maximal flexions employed, we have demonstrated shearing of blubber over muscle, with probable relevance to live dolphins and whales. Three conclusions can be drawn. First, if an intramuscular tag has to be deployed, it would be best to place it close to the dorsal midline over the thorax, while avoiding the vertebral neural spines in the midline. This location has been favored in past tagging projects (Watkins, 1981). Second, even

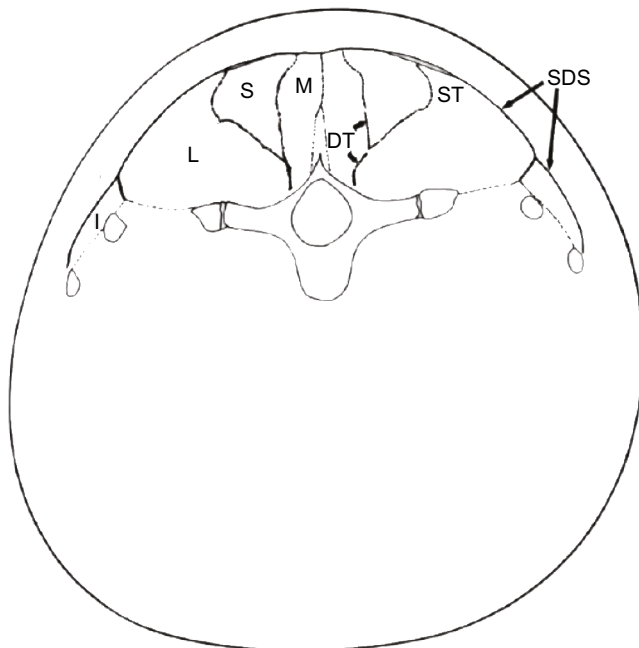

**Fig. 8. The bilaminar nature of the subdermal sheath (SDS) in the thorax of a bottlenose dolphin as illustrated by Pabst (1990).** Used with permission from John Wiley and Sons and the author. DT, deep tendon; M, multifidus; L, longissimus; S, semispinalis; SDS, sub-dermal connective sheath; ST, superficial tendon.

in the dorsal parasagittal thoracic area, there is still shearing in three of the four cases at 4-cm depth. This implies that irrespective of location, a transdermal, intramuscular tag will likely engender some degree of chronic cyclic trauma. And third, the magnitude of shearing is proportional to the depth of penetration. Needles penetrating 4-cm into the body (two to three times the blubber depth) showed substantially more shearing than those penetrating 2 cm (one times the blubber length) into the body. This is predictable given the longer lever arm from the blubber fulcrum.

Porter (1992) ascribed cetaceans to the highest level (on a spectrum from molluscs to primates) in terms of sensitivity to pain and suffering, describing them as sentient, highly intelligent and precognitive, in the same category as primates and carnivores. Despite the present study having been conducted on cadavers, the suggestion that significant cavitation is present whenever a rigid device crosses the blubber and penetrates into the muscle, and is therefore moving back and forth in the muscle as the blubber shears over the muscle, must also raise the concern that potentially substantial chronic pain at the tagging sites may be present. Any suggestion of resultant pain is subjective, but it must be recognized that a foreign body (such as a rigid satellite tag) lever within a muscle mass may result in chronic pain, especially if placement occurs in areas of the animal's body where shearing is pronounced. Nonetheless, further studies are required to better understand how cetaceans manifest pain and the implications for the behavior of the animal. While the experiments reported in the present study do not directly inform the issue of pain in the context of implanted intramuscular tags without any analgesia in the short or long term, the potential for shearing and trauma shown here would seem to suggest that even if there is no behavioral evidence of pain in the presence of these tags, there should be careful consideration of the risk of inflicting pain during the ethical review and approval of such projects. Where such tags are used it must be done responsibly and all attempts should be made to ensure that tags are placed high on the body near the dorsal midline. It is important to seek a balance of welfare and conservation in wildlife management (Bradshaw and Bateson, 2000). The benefit of the resulting data has to outweigh the animal welfare concerns for such techniques to be approved. In this context, it has been argued that 'considerations of animal welfare are not only scientifically possible and necessary, but can also assist conservation efforts by providing early indications of future conservation concerns. There is a clear scientific basis for managing human activities not only to sustain populations but also to minimize welfare impacts on individual animals' (Papastavrou et al., 2017).

These findings therefore warrant further consideration of the possibility of engineering tags that can remain attached for multiple months without penetrating into the muscle. Blubber-only tags have been used recently, albeit with retention times of days (Baumgartner et al., 2015). Thus before an effective long-term blubber-only tag can be developed, there has to be fundamental new understanding of how to engineer a tag structure that enables retention within the blubber. The principles used for the development of long-term human surgical implants should be reviewed and developed (Gunatillake and Adhikari, 2003). In addition, it also makes sense to consider developing tags that still penetrate the sub-dermal sheath that minimize trauma by anchoring at the fascia, but compensate for shearing.

#### Acknowledgements

We thank Terry Hammar, Jason Kapit, Miles Ochs, Henry Gleason, Eric Hayden and Misty Niemeyer for their assistance.

#### Competing interests

The authors declare no competing or financial interests.



**Author contributions**

Conceptualization: M.J.M., A.N.Z.; Methodology: M.J.M., A.N.Z.; Validation: M.J.M., A.N.Z.; Formal analysis: M.J.M., A.N.Z.; Investigation: M.J.M., A.N.Z.; Resources: M.J.M.; Data curation: M.J.M.; Writing - original draft: M.J.M.; Writing - review & editing: M.J.M., A.N.Z.; Visualization: M.J.M., A.N.Z.; Project administration: M.J.M., A.N.Z.; Funding acquisition: A.N.Z.

**Funding**

This study was undertaken with support from the Office of Naval Research (award no. N00014-13-1-0653 to Cascadia Research Collective).

**Supplementary information**

Supplementary information available online at <http://jeb.biologists.org/lookup/doi/10.1242/jeb.165282.supplemental>

**References**

- Andrews, R. D., Pitman, R. L. and Ballance, L. T.** (2008). Satellite tracking reveals distinct movement patterns for Type B and Type C killer whales in the southern Ross Sea, Antarctica. *Polar Biol.* **31**, 1461–1468.
- Baumgartner, M. F., Hammar, T. and Robbins, J.** (2015). Development and assessment of a new dermal attachment for short-term tagging studies of baleen whales. *Methods Ecol. Evol.* **6**, 289–297.
- Best, P. and Mate, B.** (2007). Sighting history and observations of southern right whales off South Africa. *J. Cetacean Res. Manag.* **9**, 111–114.
- Best, P. B., Mate, B. and Lagerquist, B.** (2015). Tag retention, wound healing, and subsequent reproductive history of southern right whales following satellite-tagging. *Mar. Mamm. Sci.* **31**, 520–539.
- Bradshaw, E. L. and Bateson, P.** (2000). Animal welfare and wildlife conservation. In *Behaviour and Conservation* (ed. L. M. Gosling and W. J. Sutherland), pp. 330–348. Cambridge: Cambridge University Press.
- Brown, S. G.** (1978). Whale marking techniques. In *Animal Marking Techniques* (ed B. Stonehouse), pp. 71–80. London: Springer.
- Etnier, S. A., McLellan, W. A., Blum, J. and Pabst, D. A.** (2008). Ontogenetic changes in the structural stiffness of the tailstock of bottlenose dolphins (*Tursiops truncatus*). *J. Exp. Biol.* **211**, 3205–3213.
- Gales, N., Double, M., Robinson, S., Jenner, C., Jenner, M. N. M., King, E., Gedamke, J., Paton, D. and Raymoind, B.** (2009). Satellite tracking of southbound East Australian humpback whales (*Megaptera novaengliae*): challenging the feast or famine model for migrating whales. Paper SC/61/SH17 presented at the International Whaling Commission Scientific Committee, Funchal, Madeira Island.
- Gendron, D., Serrano, I. M., de la Cruz, A. U., Calambokidis, J. and Mate, B.** (2015). Long-term individual sighting history database: an effective tool to monitor satellite tag effects on cetaceans. *Endangered Species Res.* **26**, 235–241.
- Gunatillake, P. A. and Adhikari, R.** (2003). Biodegradable synthetic polymers for tissue engineering. *European Cells Mater.* **5**, 1–16.
- Mate, B., Mesecar, R. and Lagerquist, B.** (2007). The evolution of satellite-monitored radio tags for large whales: one laboratory's experience. *Deep-Sea Res.* **54**, 224–247.
- Miller, C. A., Reeb, D., Best, P. B., Knowlton, A. R., Brown, M. W. and Moore, M. J.** (2011). Blubber thickness in right whales *Eubalaena glacialis* and *Eubalaena australis* related with reproduction, life history status and prey abundance. *Mar. Ecol. Prog. Ser.* **438**, 267–283.
- Moore, M. J., Miller, C. A., Morss, M. S., Arthur, R., Lange, W. A., Prada, K. G., Marx, M. K. and Frey, E. A.** (2001). Ultrasonic measurement of blubber thickness in right whales. *J. Cetacean Res. Manag. Spec. Issue* **2**, 301–309.
- Moore, M., Andrews, R., Austin, T., Bailey, J., Costidis, A., George, C., Jackson, K., Pitchford, T., Landry, S., Ligon, A. et al.** (2013). Rope trauma, sedation, disentanglement, and monitoring-tag associated lesions in a terminally entangled North Atlantic right whale (*Eubalaena glacialis*). *Mar. Mamm. Sci.* **29**, E98–E113.
- Pabst, D. A.** (1990). Axial muscles and connective tissues of the bottlenose dolphin. In *The Bottlenose Dolphin* (ed. S. Leatherwood and R. Reeves), pp. 51–67. San Diego, CA: Academic Press.
- Pabst, D. A.** (1993). Intramuscular morphology and tendon geometry of the epaxial swimming muscles of dolphins. *J. Zool.* **230**, 159–176.
- Papastavrou, V., Leaper, R. and Lavigne, D.** (2017). Why management decisions involving marine mammals should include animal welfare. *Marine Policy* **79**, 19–24.
- Porter, D. G.** (1992). Ethical scores for animal experiments. *Nature* **356**, 101–102.
- Robbins, J., Zerbini, A., Gales, N., Gulland, F., Double, M., Clapham, P., Andrews-Goff, V., Kennedy, A., Landry, S., Mattila, D. et al.** (2013). Satellite tag effectiveness and impacts on large whales: preliminary results of a case study with Gulf of Maine humpback whales. Document SC/65a/SH05 presented to the IWC Scientific Committee, Jeju, South Korea, June 2013. International Whaling Commission Secretariat.
- Videler, J. and Kamermans, P.** (1985). Differences between upstroke and downstroke in swimming dolphins. *J. Exp. Biol.* **119**, 265–274.
- Watkins, W. A.** (1981). Reaction of three species of whales *Balaenoptera physalus*, *Megaptera novaengliae* and *Balaenoptera edeni* to implanted radio tags. *Deep-Sea Res.* **28A**, 589–599.
- Zerbini, A. N., Andriolo, A., Heide-Jørgensen, M. P., Pizzorno, J. L., Maia, Y. G., VanBlaricom, G. R., DeMaster, D. P., Simões-Lopes, P. C., Moreira, S. and Bethlem, C.** (2006). Satellite-monitored movements of humpback whales *Megaptera novaengliae* in the Southwest Atlantic Ocean. *Mar. Ecol. Prog. Ser.* **313**, 295–304.

**Table S1** - Shearing angles measured during dorsal and ventral flexion of four common dolphins and subsequent calculations as illustrated in Figures 1, 2 and 3 and described in text.

[Click here to Download Table S1](#)