

## RESEARCH ARTICLE

# Use of the swim bladder and lateral line in near-field sound source localization by fish

Allison B. Coffin<sup>1,2,\*</sup>, David G. Zeddies<sup>3,§</sup>, Richard R. Fay<sup>4</sup>, Andrew D. Brown<sup>5,‡</sup>, Peter W. Alderks<sup>6</sup>, Ashwin A. Bhandiwad<sup>6</sup>, Robert A. Mohr<sup>6</sup>, Michael D. Gray<sup>7</sup>, Peter H. Rogers<sup>7</sup> and Joseph A. Sisneros<sup>1,6,8,¶</sup>

**ABSTRACT**

We investigated the roles of the swim bladder and the lateral line system in sound localization behavior by the plainfin midshipman fish (*Porichthys notatus*). Reproductive female midshipman underwent either surgical deflation of the swim bladder or cryoablation of the lateral line and were then tested in a monopolar sound source localization task. Fish with nominally ‘deflated’ swim bladders performed similar to sham-deflated controls; however, post-experiment evaluation of swim bladder deflation revealed that a majority of ‘deflated’ fish (88%, seven of the eight fish) that exhibited positive phonotaxis had partially inflated swim bladders. In total, 95% (21/22) of fish that localized the source had at least partially inflated swim bladders, indicating that pressure reception is likely required for sound source localization. In lateral line experiments, no difference was observed in the proportion of females exhibiting positive phonotaxis with ablated (37%) versus sham-ablated (47%) lateral line systems. These data suggest that the lateral line system is likely not required for sound source localization, although this system may be important for fine-tuning the approach to the sound source. We found that midshipman can solve the 180 deg ambiguity of source direction in the shallow water of our test tank, which is similar to their nesting environment. We also found that the potential directional cues (phase relationship between pressure and particle motion) in shallow water differs from a theoretical free-field. Therefore, the general question of how fish use acoustic pressure cues to solve the 180 deg ambiguity of source direction from the particle motion vector remains unresolved.

**KEY WORDS:** Hearing, Lateral line, Phonotaxis, Swim bladder

**INTRODUCTION**

Fish are well equipped to detect underwater acoustic and vibratory stimuli. Most teleost fishes have both auditory and lateral line systems, and each system is responsive to the local fields produced by acoustic and/or vibratory sources. These systems are used in a

variety of behavioral contexts, including behaviors such as prey detection and mate selection, which necessitate sound source orientation and localization (Fay, 2005; Webb et al., 2008). While several studies have established that some fishes can determine sound direction and localize underwater sound sources (Schuijf, 1975; Schuijf and Hawkins, 1983; Zeddies et al., 2010; Zeddies et al., 2012), there is much debate over the mechanism(s) underlying sound source localization ability (see Fay and Simmons, 1999; Rogers and Zeddies, 2008). Sound pressure is a scalar quantity containing no information about direction, and thus is in itself not useful for determining sound source direction. The particle motion component of sound, in contrast, is a vector quantity (containing a directional component) and could thus be useful for determining the direction to a sound source. Fishes possess two systems for particle motion detection, the inner ear and the lateral line (Braun and Coombs, 2000; Braun and Coombs, 2010). Based on his work on the lateral line organs of killifish (*Fundulus heteroclitus*), van Bergeijk suggested that pressure reception by the inner ear allowed for detection of a sound source but that the lateral line system was responsible for supplying directional information (Harris and Van Bergeijk, 1962; Van Bergeijk, 1967). Years later, the relative contributions of the inner ear and lateral line to particle motion detection and source localization are still not firmly understood.

Particle motion detection by the inner ear alone seems insufficient for signaling the direction to a sound source because the axis of the particle motion vector points both towards and away from the source, meaning there is a ‘180 deg ambiguity’ that remains unresolved without further information (Fay, 2005). In other words, fish sensitive only to particle motion should be able to identify the axis along which the local particle motion lies, but unable to distinguish whether the source is located at one heading or at 180 deg in the opposite direction. Current models for sound source localization by fish depend on the detection and processing of both the pressure and particle motion components of sound for the resolution of this ambiguity (Fay, 2005). A major assumption of several related hypotheses (Chapman and Hawkins, 1973; Schuijf, 1975), including a dominant hypothesis of sound source localization known as the ‘phase model’ (Schuijf and Buwalda, 1975), holds that fishes are able to use the phase difference of sound pressure and particle motion components to compute the direction to a sound source (resolving the 180 deg ambiguity). However, these models assume a far-field pressure–particle velocity relationship and require sinusoidal stimuli. An alternative computational model proposed by Rogers et al. (Rogers et al., 1988) for resolving the 180 deg ambiguity also requires that fish detect both sound pressure and particle motion, but works at all distances from a simple monopole sound source and does not require sinusoidal signals. For sinusoidal signals, the Schuijf and Rogers models make identical predictions, dependent on the phase difference of the pressure and particle velocity components.

<sup>1</sup>Virginia Merrill Bloedel Hearing Research Center, University of Washington, Seattle, WA 98195, USA. <sup>2</sup>Department of Otolaryngology – Head and Neck Surgery, University of Washington, Seattle, WA 98105, USA. <sup>3</sup>JASCO Applied Sciences, Silver Spring, MD 20902, USA. <sup>4</sup>Marine Biological Laboratory, Woods Hole, MA 02543, USA. <sup>5</sup>Department of Speech and Hearing Sciences, University of Washington, Seattle, WA 98105, USA. <sup>6</sup>Department of Psychology, University of Washington, Seattle, WA 98195, USA. <sup>7</sup>George W. Woodruff School of Mechanical Engineering, Georgia Institute of Technology, Atlanta, GA 30332, USA. <sup>8</sup>Department of Biology, University of Washington, Seattle, WA 98195, USA. \*Present address: Washington State University Vancouver, Vancouver, WA 98686, USA. †Present address: University of Colorado School of Medicine, Aurora, CO 80045, USA.

§These authors contributed equally to this work

¶Author for correspondence (sisneros@u.washington.edu)

Received 11 July 2013; Accepted 13 March 2014

It is highly likely that all fishes are able to detect the particle motion component of sound via the inner ear otolithic end organs, which function as inertial accelerometers (De Vries, 1950; Dijkgraaf, 1960; Fay, 1984). Recent behavioral studies with the plainfin midshipman fish (*Porichthys notatus* Girard 1854) show that these fish can use local acoustic particle motion to locate a sound source (Zeddies et al., 2010; Zeddies et al., 2012). The extent to which midshipman fish are receptive to sound pressure, or able to resolve the 180 deg ambiguity problem via pressure reception, is not known. More generally, the role that pressure reception or the mechanosensory lateral line, which is sensitive to both particle motion and local pressure gradients (Webb et al., 2008), may play in sound source localization remains empirically untested.

Here, we investigate the use of the swim bladder and lateral line in sound source localization by female plainfin midshipman in the near field, wherein the source distance is less than an acoustic wavelength and the ratio of pressure to radial particle velocity is a distance-dependent complex value smaller in magnitude than the density–sound speed product. Experiments were conducted during the summer of 2010 on wild-caught females in reproductive condition. Across experiments, stimuli were simulated advertisement calls of male midshipman fish, which are approximately sinusoidal (Bass, 1992), and thus well suited to test the predictions of sound source localization models. Our findings suggest that (1) pressure reception is likely required for near-field source localization, (2) midshipman can resolve the 180 deg ambiguity, though the mechanisms for doing so remain obscure, and (3) the lateral line system may not be necessary for near-field source localization.

## RESULTS

### Acoustic field characterization

The spatial characteristics of the acoustic field generated by the J-9 and AQ339 sound projectors were quantified from the tank mapping measurements made with miniature hydrophones (sound pressure) and a tri-axial accelerometer (particle motion). For arcs of constant radius from the source, the azimuthal standard deviation of the pressure at 90 Hz was found to be no more than 10% and 6% for the J-9 and AQ339 projectors, respectively. Standard deviation values at 75 and 80 Hz for the AQ339 were 9% and 6%, respectively. These results confirmed that the sound fields were circumferentially uniform (axisymmetric) within the mapped area of the sound field that contained the fish release points and phonotactic paths of the tested fish.

### Biased and unbiased release experiments

Sound playback experiments were conducted at night in an outdoor cylindrical concrete tank, with initial release sites and the speaker position as indicated in Fig. 1. In this first experiment, we asked whether there was a difference in localization behavior for fish that were released so that their initial swimming direction was biased towards the sound source (biased release) versus fish that were allowed to leave the release site in any direction (unbiased release). The phonotactic responses displayed in the biased versus unbiased release experiments were unambiguous; positive phonotactic responses entailed repeated contact with the source by the fish [see Zeddies et al. (Zeddies et al., 2010) for descriptions of the phonotactic response]. Of the 17 reproductive females tested in the ‘unbiased’ (open) release, 65% ( $n=11$ ) exhibited a positive phonotactic response. Of the 31 reproductive females tested in the ‘biased’ release experiments, 61% ( $n=19$ ) exhibited positive phonotactic responses. A logistic regression showed that there was

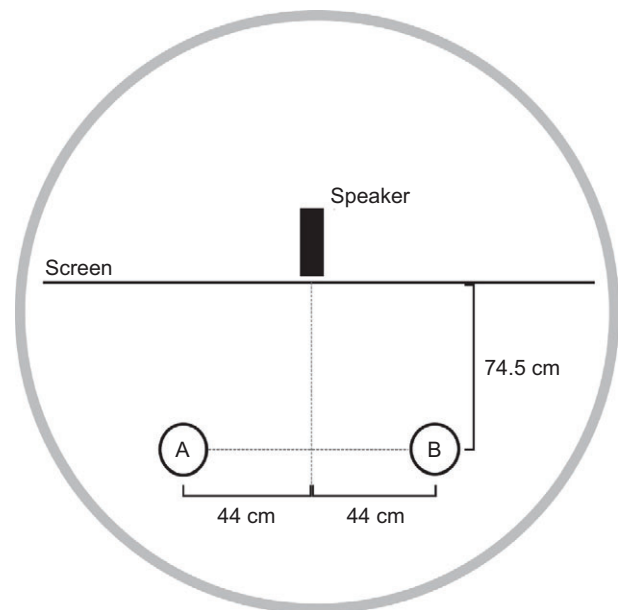
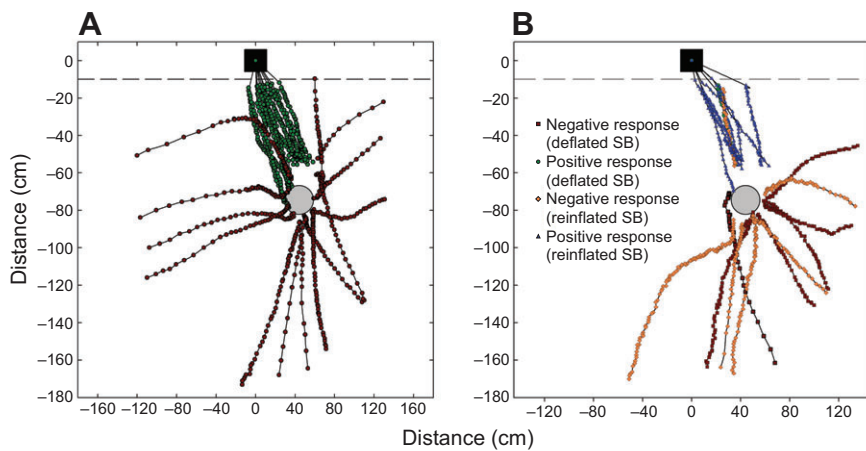

**Fig. 1. Schematic of the experimental setup (tank diameter=4 m, water depth=50 cm).** Shown is the monopole sound source (Lubell AQ339, Clark Synthesis, Littleton, CO, USA, or a US Navy J-9 transducer), the opaque screen and the animal release sites (A and B).

no difference in the proportion of females that exhibited positive phonotactic responses in the biased (61%) release experiments compared with the unbiased (65%) release experiments [ $\beta=0.14\pm0.67$  (mean  $\pm$  s.e.m.),  $t=0.23$ ,  $P=0.82$ ], suggesting that fish were able to resolve the 180 deg ambiguity.

### Swim bladder deflation experiments

Phonotactic responses were next examined in fish with intact or deflated swim bladders to determine whether the swim bladder was required for near-field sound source localization. Of the 28 reproductive females with sham-deflated swim bladders, 50% ( $n=14$ ) exhibited positive phonotactic responses; the trajectories these females took after release from Site B are shown in Fig. 2A. Of the 21 reproductive females that underwent swim bladder deflation surgery, 38% ( $n=8$ ) exhibited positive phonotactic responses (see Fig. 2B). An initial logistic regression analysis indicated no difference in the proportion of females with ‘deflated’ (38%) and sham-deflated (50%) swim bladders that exhibited positive phonotaxis [ $\beta=0.49\pm0.59$  (mean  $\pm$  s.e.m.),  $t=0.83$ ,  $P=0.41$ ]. However, upon postmortem examination of the fish that underwent swim bladder deflation surgery, we found that 12 (out of 21) had partially (25 to 50%) to nearly completely (>90%) inflated swim bladders. The observation of partial swim bladder inflation within 24 h post deflation surgery (and <12 h post-test) suggests rapid re-inflation of the swim bladder in this subset of animals. We thus compared, *post hoc*, fish with re-inflated swim bladders (fish with greater than 25% swim bladder re-inflation,  $n=12$ ) against those with still-deflated swim bladders (fish with 100% swim bladder deflation). Whereas 58% ( $n=7$ ) of ‘re-inflated’ fish exhibited positive phonotaxis – a proportion not significantly different from that in sham-deflated controls ( $\beta=-0.34\pm0.67$ ,  $t=0.48$ ,  $P=0.68$ ) – only one of nine ‘still-deflated’ fish exhibited positive phonotaxis – a proportion significantly lower than in the re-inflated sub-group ( $\beta=2.41\pm1.21$ ,  $t=1.99$ ,  $P<0.05$ ). In sum, we found that 95% (21/22) of fish that localized the source had at least partially inflated swim



**Fig. 2. Phonotactic response pathways of reproductive female midshipman fish that underwent swim bladder deflation surgery.** (A) Response pathways of females with sham-deflated swim bladders that exhibited positive (green circles) and negative (red circles) responses to the simulated advertisement call stimulus. (B) Response pathways of females with deflated and re-inflated swim bladders (see Results) that exhibited positive phonotaxis with either deflated (green circles) or re-inflated (blue triangles) swim bladders and negative responses with either deflated (red squares) or re-inflated (orange diamonds) swim bladders. The axes are the distance from the center of the tank (cm), where the monopole J-9 speaker (black square) was located, and the dotted line represents the position of the opaque screen. Grey circles indicate the position of the plastic mesh cylinder where the animals were released.

bladders, indicating that pressure reception is likely required for sound source localization.

### Lateral line ablation experiments

#### Morphology

Phonotaxis responses were next examined in fish with ablated lateral line systems in order to determine the relative contribution of the lateral line to source localization. Lateral line ablation was achieved with a liquid  $N_2$ -dipped probe. Cryoablation success was qualitatively verified with DASPEI in a subset of fish immediately after sound source localization experiments were performed (see Fig. 3 for an illustration of lateral line morphology). DASPEI-labeled neuromasts were present in stereotyped patterns on the head, trunk and tail of intact and sham-ablated fish, while DASPEI labeling was largely absent from neuromasts in ablated fish (Fig. 4). Only superficial neuromasts (SN) could be verified in this way because of the dark skin pigmentation of the skin that obscured canal neuromast (CN) visualization, and because of the superglue over the canals in ablated animals. SN ablation was quantified in fixed FM 1-43FX-labeled animals as described in the Materials and methods (Fig. 5, Table 1). Regions used for quantification are indicated in Fig. 3. There were  $16.1 \pm 6.7\%$  SN (mean  $\pm$  s.d.) remaining in liquid  $N_2$ -ablated, FM-labeled fish ( $n=9$  fish, 177–254

SN quantified per fish), with the highest percentage of intact neuromasts observed on the mandible ( $38.9 \pm 15.8\%$ ) and the lowest percentage seen on the dorsal trunk line ( $4.9 \pm 6.3\%$ ; Table 1). Two

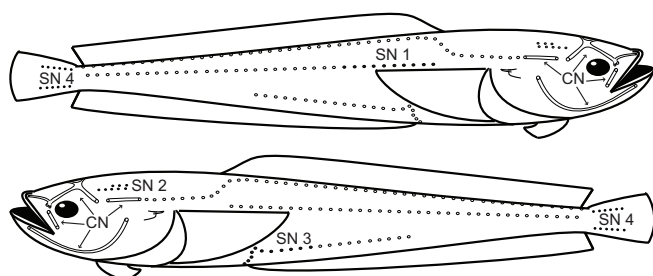

**Fig. 3. Schematic illustration of the plainfin midshipman fish lateral line mechanosensory system (adapted from Greene, 1899).** All illustrated neuromasts and several stitches not illustrated [superficial neuromasts (SN) primarily on the head and underbelly] were targeted for ablation. Four regions of SN were selected for phalloidin labeling (neuromasts filled in black): a 2 cm region from the right dorsal line starting at the anterior edge of the dorsal fin (SN 1), a 1 cm region on the top of the head (left side; SN 2), 1.5–2 cm from the ventral line (left side) starting at the anterior edge of the anal fin (SN 3), and the entire caudal fin (SN 4). Given the small number of canal neuromasts (CN) in this species, all canals were dissected from the head and labeled rather than selecting discrete CN regions for sub-sampling (arrows; neuromasts within canals not illustrated).

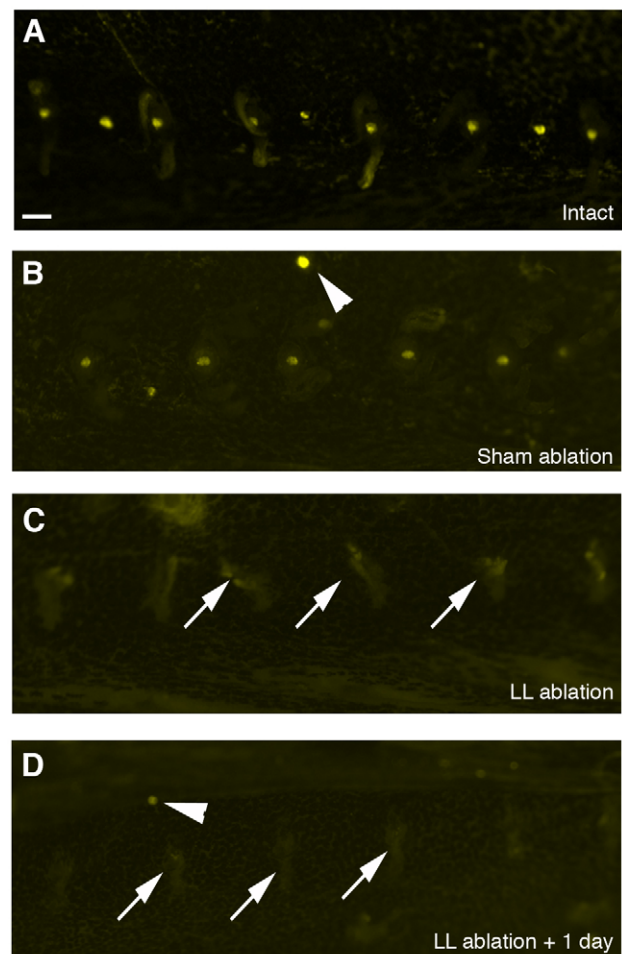

**Fig. 4. DASPEI labeling of neuromasts in live, anesthetized female midshipman.** Images are from the dorsal lateral line that runs along the base of the dorsal fin. (A) Intact animal; (B) sham-operated animal (ventral photophores ablated); (C) lateral line ablation performed same day; (D) lateral line ablation performed 1 day prior to behavioral testing and imaging. Arrows in C and D delineate examples of neuromast locations. Arrowheads in B and D indicate photophores, which are autofluorescent. Scale bar in A, 500  $\mu$ m (applies to all panels).

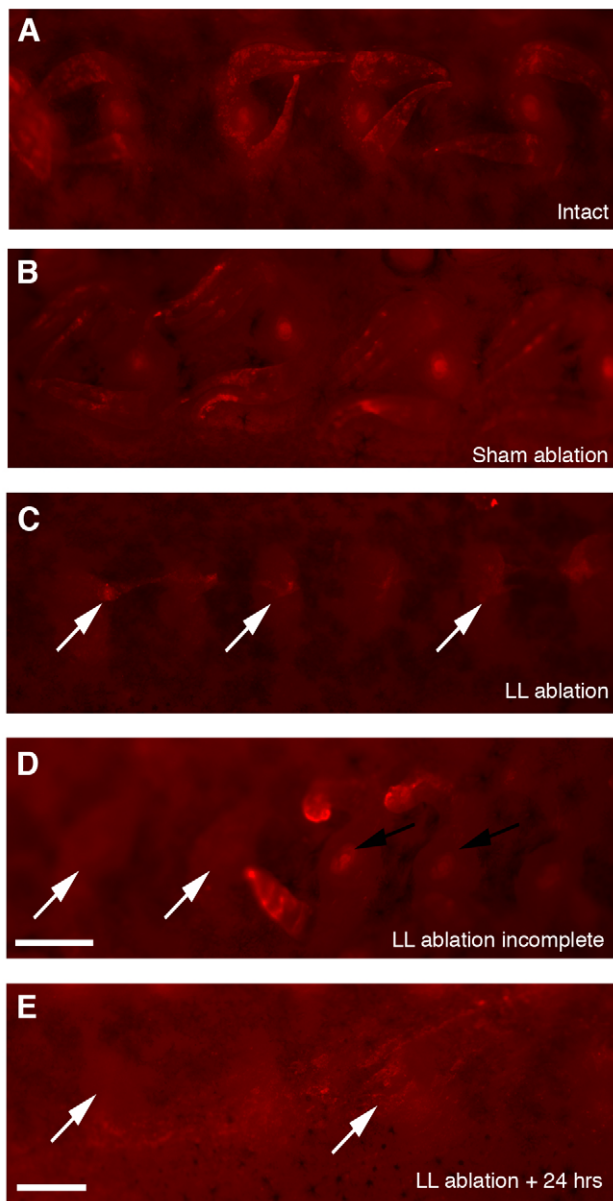

**Fig. 5. FM 1-43FX-labeled neuromasts in fixed animals.** Images are from the ventromedial surface between the pectoral fins. (A) Intact animal; (B) sham-operated animal; (C,D) lateral line ablation performed same day; (E) lateral line ablation performed 1 day prior to behavioral testing and imaging. White arrows in C–E show examples of neuromast locations where all hair cells were successfully ablated. Black arrows in D point to remaining neuromasts in a fish subjected to liquid N<sub>2</sub> ablation. Scale bars, 500  $\mu$ m.

fish with 17.4% and 9.6% intact SN failed to localize the sound source, while a fish with only 6.8% remaining SN localized the sound source, suggesting that the positive phonotaxis seen in many of the ablated fish was not due to excess intact neuromasts.

Neuromast structure was visualized in both SN and CN using phalloidin labeling, as shown in Fig. 6. The small papillae are clearly visible in intact SN, with a patch of hair bundles lying between the two papillae (Fig. 6A,B). Intact CN are larger and have many more hair bundles than SN (compare Fig. 6B and 6C) and lack peripheral papillae. These papillae are damaged in ablated SN and the hair bundles and surrounding epithelial layer are absent (Fig. 6D,E). Ablated CN can be recognized by the epithelial

morphology surrounding the usual hair-cell-containing region (Fig. 6F). Intact CN were occasionally detected in ablated fish at a frequency of  $\sim 1$  intact CN per animal; however, CN were not quantified as we could not be certain that some were not damaged during postmortem dissection. It is unlikely that the few remaining CN in ablated fish received any stimulation because of the superglue that obstructed the incurrent and excurrent openings to the canals.

#### Localization behavior

Of the 35 reproductive females that had their lateral line system ablated, 37% ( $n=13$ ) exhibited positive phonotactic responses. The pathways these females took after release from Site A are shown in Fig. 7A. Of the 15 reproductive females that had sham-ablated lateral lines (photophores only), 47% ( $n=7$ ) exhibited positive phonotactic responses. Swimming pathways for these fish after release from Site A are shown in Fig. 7B. Because some experiments were conducted the day after lateral line ablation, a hierarchical logistic regression was performed to control for the effect of day. There was a significant increase in response on the day after lateral line ablation in both lateral-line-ablated (28% on Day 1, 55% on Day 2) and sham-ablated animals (28% on Day 1, 50% on Day 2) [ $\beta=1.75\pm 0.75$  (mean  $\pm$  s.e.m.),  $t=2.33$ ,  $P=0.02$ ]. However, controlling for the effect of day, there was no difference in the proportion of females with ablated (37%) and sham-ablated (47%) lateral lines that exhibited positive phonotaxis ( $\beta=0.67\pm 0.69$ ,  $t=0.97$ ,  $P=0.33$ ). A mean vector analysis of the swimming pathways at the initial release showed that the direction of movement was biased towards the sound source ( $P<0.001$  for both ablated and sham-ablated lateral line females).

The angles that the positive phonotactic fish took (after released from Site A) were compared for females with ablated and sham-ablated lateral line systems. The mean orientation error relative to the source was significantly different at the initial release for lateral-line-ablated females (mean orientation error=39.0 deg) compared with lateral line sham-ablated females (mean orientation error=15.3 deg) (Watson–Williams test,  $F_{1,18}=6.3$ ,  $P<0.025$ ). In addition, the mean orientation relative to the source at the midpoint of the phonotactic pathway taken was also significantly different for lateral-line-ablated females (mean orientation error=33.4 deg) compared with lateral line sham-ablated females (mean orientation error=12.8 deg) (Watson–Williams test,  $F_{1,18}=6.39$ ,  $P<0.025$ ).

#### DISCUSSION

The plainfin midshipman fish is a good model to explore how fishes localize underwater sound sources (Zeddies et al., 2010; Zeddies et al., 2012), in part because reproductive females exhibit robust phonotactic responses to the underwater acoustic playback of natural and synthetic male advertisement calls (Bass et al., 1999; McKibben and Bass, 2001). Previously, we demonstrated that the plainfin midshipman fish can use local acoustic particle motion to guide the animal to a sound source (Zeddies et al., 2010; Zeddies et al., 2012), but the contribution of swim bladder pressure cues and the mechanosensory lateral line to sound source localization remained unresolved. Thus, the primary objective of this study was to determine whether the swim bladder and/or the lateral line were required for near-field sound source localization. Our findings suggest that pressure reception is likely required for near-field sound source localization, that fish can solve the 180 deg ambiguity inherent in the particle motion vector, and that the lateral line system is likely not necessary for near-field sound source localization. It is important to note, however, that these experiments were performed

**Table 1. Quantification of FM-labelled superficial neuromasts (SN) from six regions of liquid N<sub>2</sub>-ablated fish (n=9)**

Fish	Dorsal line		Top of head		Belly		Lower jaw		Caudal fin		Operculum		Total	
	Intact (%)	Total	Intact (%)	Total	Intact (%)	Total	Intact (%)	Total	Intact (%)	Total	Intact (%)	Total	Intact (%)	Total
376	3 (3.9)	76	0 (0)	13	0 (0)	43	9 (22.5)	40	23 (33.8)	68	3 (21.4)	14	38 (15.0)	254
377	16 (20.8)	77	0 (0)	9	7 (14)	50	28 (65.0)	43	10 (40.0)	25	1 (6.7)	15	62 (28.3)	219
391 <sup>a</sup>	0 (0)	88	0 (0)	10	5 (15.6)	32	16 (57.1)	28	14 (29.8)	47	3 (23.1)	13	38 (17.4)	218
392 <sup>a</sup>	0 (0)	73	4 (40)	10	3 (7.1)	42	11 (33.3)	33	2 (5.3)	38	0 (0)	12	20 (9.6)	208
432	4 (5.2)	77	1 (7.1)	14	0 (0)	49	23 (52.3)	44	0 (0)	32	1 (5.5)	18	29 (12.4)	234
433 <sup>b</sup>	5 (5.5)	90	0 (0)	13	1 (2.1)	47	16 (40.0)	40	13 (31.7)	41	0 (0)	15	35 (14.2)	246
441	4 (4.5)	89	0 (0)	8	0 (0)	50	9 (31.0)	29	28 (70.0)	40	1 (5.9)	17	42 (18.0)	233
447	2 (2.8)	70	0 (0)	10	10 (20.0)	50	8 (22.2)	36	33 (78.6)	42	0 (0)	18	53 (23.4)	226
449	1 (1.6)	62	0 (0)	11	0 (0)	24	10 (26.3)	38	0 (0)	27	1 (6.7)	15	12 (6.7)	177

Data are presented as the number and percentage of intact SN (as visualized with FM) relative to the total number of SN. Neuromast position was determined by epithelial morphology (e.g. fleshy papillae) and pigmentation differences as compared with the surrounding non-sensory areas, allowing for unambiguous identification of SN even in the absence of FM labeling. Data for sham-ablated animals are not shown but missing neuromasts were rarely seen in these animals (0–2 unlabeled SN per fish).

<sup>a</sup>Ablated fish that did not localize the sound source.

<sup>b</sup>Phonotactic response, FM labeling and euthanasia occurred 1 day post-ablation.

in a benthic species that inhabits an extreme shallow-water environment (during the breeding season), and therefore our results may not pertain to all fishes, especially pelagic species that live in the water column.

### Sound pressure reception and resolving the 180 deg ambiguity

During an acoustic disturbance, an infinitesimal ‘particle’ of fluid undergoes a small linear displacement of oscillating polarity. In the present case, with an axisymmetric sound field, the particle motion vector alternately points towards and away from the acoustic source for equal amounts of time. Therefore, this particle motion vector does not indicate which direction along the line to follow in order to reach the source, giving rise to the so-called 180 deg ambiguity in particle motion. The behavioral capacity for directional-dependent hearing in fish has been demonstrated [e.g. directional masking in Atlantic cod *Gadus morhua* (Hawkins and Sand, 1977); sound source localization in plainfin midshipman (Zeddies et al., 2010; Zeddies et al., 2012)], but there were no data to demonstrate that fish solve the 180 deg ambiguity problem during sound source localization. In the present study we found no difference in the positive phonotactic response rate when fish were allowed to swim in any direction upon release (‘unbiased’ release) versus when they were directed toward the sound source upon release (‘biased’ release). We also found that the positive response rate was >60% in both release cases. If fish could not solve the 180 deg ambiguity, biasing their release toward the source would be expected to increase the positive phonotactic response rate relative to that for the unbiased release, as in the unbiased condition, fish able to detect the source axis but unable to determine ‘front’ from ‘back’ would be expected to swim away from the source in approximately half of trials. Moreover, no fish were observed to exit away from the sound source and then correctly turn and move to the sound source (Fig. 2). Therefore, because the positive phonotactic response rate was the same in both release conditions, and the positive response rate in the unbiased situation was >60%, we suggest that midshipman effectively resolve the 180 deg ambiguity problem during sound source localization. While it is true that a subset of fish in all experiments failed to localize the sound source, the majority of these fish did not swim 180 deg in the opposite direction, as would be expected if they were motivated to locate the source but could not solve the 180 deg ambiguity. Instead, some of the non-localizing fish remained at the release site, while the others swam in various

directions towards the edges of the tank, at which point the trial was terminated.

The relationship between particle motion and pressure is central to hypotheses concerning the basis of sound source localization by fish, notably the ‘phase model’ suggested by Schuijff and Buwalda (Schuijff and Buwalda, 1975) and the more general model of Rogers et al. (Rogers et al., 1988). In these models, fish must be receptive to particle motion and pressure in order to solve the 180 deg ambiguity. To assess the role that pressure reception may play in sound source localization by midshipman, we attempted to deflate the swim bladder in a subset of animals. Collectively, 95% of fish (21/22) that exhibited a positive phonotactic response had at least partially inflated swim bladders (seven re-inflated, 14 sham deflated), while only a single fish with a fully deflated swim bladder (1/9) exhibited a positive phonotactic response. Taken together, these results suggest that sound pressure is likely an important cue used in sound source localization by these fish. The overall reduction in phonotaxis and sound localization in fish with intact or re-inflated swim bladders compared with females in previous studies (Zeddies et al., 2010; Zeddies et al., 2012) is likely due to the after effects of anesthesia and the observed reduction in swimming behavior in recently anesthetized midshipman that were surgically manipulated, a phenomenon also seen in the lateral line ablation experiments (J.A.S. and A.B.C., data not shown).

Although it is apparent that sound pressure is used for source localization by the plainfin midshipman fish, it is not clear how the pressure cue is used to solve the 180 deg ambiguity problem. The ‘phase model’ (Schuijff and Buwalda, 1975) was developed based on experiments using approximately planar wave conditions, wherein sound pressure and radial particle velocity are in phase, having the same or opposite polarity depending on the direction of propagation. The propagation direction–polarity relationship persists for the in-phase components of the pressure and particle velocity even in the near field for a free-field point source. This is the basis of the Rogers et al. (Rogers et al., 1988) algorithm for resolving the ambiguity. However, for the propagation conditions in our test tank and for some natural environments, including the midshipman nesting environment, the phase relationship between sound pressure and radial particle velocity is more complicated, and can be significantly different from the field of a free-field point source. We discuss these differences in depth in a modeling study described in the Appendix. In short, our results indicate that if a fish responded correctly to a free-field source (at any range), it would actually respond in the

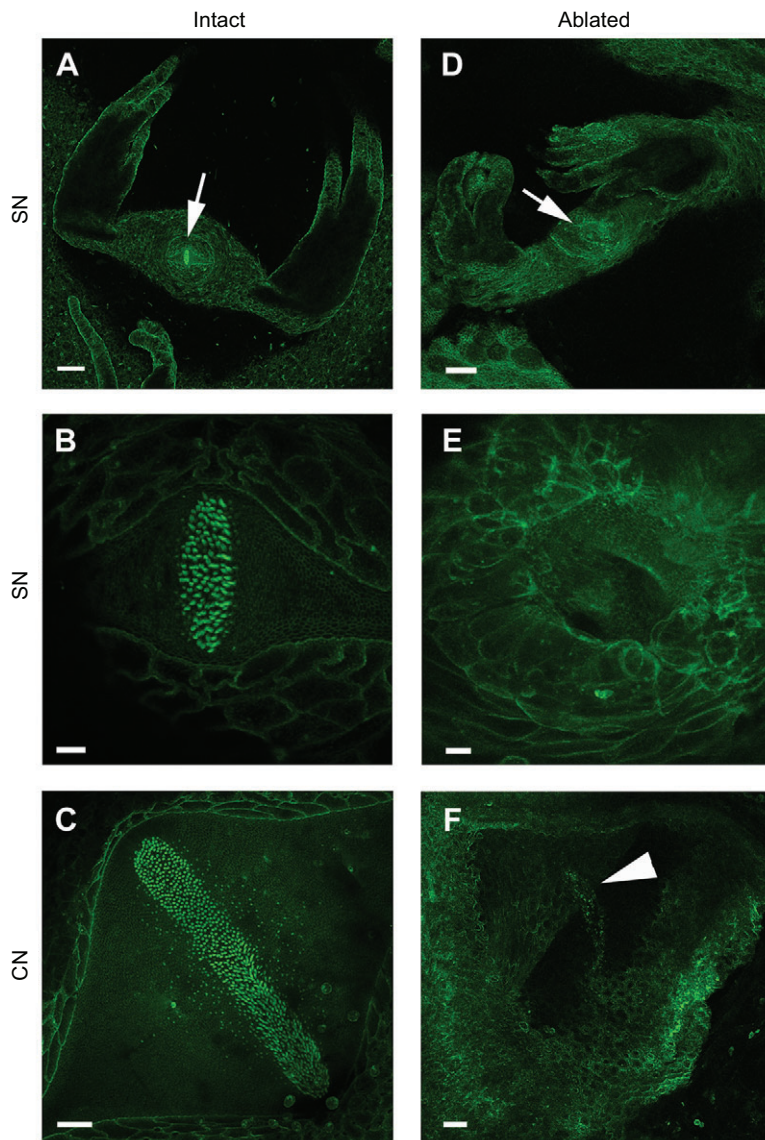

**Fig. 6. Phalloidin-labeled neuromasts from intact (A–C) and ablated (D–F) animals.** (A) Low-magnification image of a ventral SN showing intact papillae. The neuromast between these structures is indicated with an arrow and is shown at higher magnification in B. (C) Intact CN with a full complement of hair bundles. (D) Low-magnification image of a damaged ventral SN. The papillae are still present but appear damaged. The arrow indicates the position of the ablated neuromast, which is shown in higher magnification in E. (F) Liquid N<sub>2</sub>-ablated CN. The arrowhead marks scattered hair bundle remnants. Scale bars, 100 μm (A,D); 10 μm (B,E); 30 μm (C,F).

wrong direction during phonotaxis in the non-free-field Bodega Bay tank. Similarly, our propagation models for conditions similar to the natural nesting environment of the midshipman indicate that if a fish responded in the correct direction for a free-field point source, it would also respond in the wrong direction in the nesting environment at distances that ranged from 1 cm to 25–50 m

depending on bottom type. Ultimately, because female midshipman consistently exhibited positive phonotaxis in our test tank, we are left to conclude that different source localization strategies are used in shallow-water versus free-field environments, or that midshipman are unable to correctly resolve the 180 deg ambiguity in deep water. Future studies will be required to determine which of these

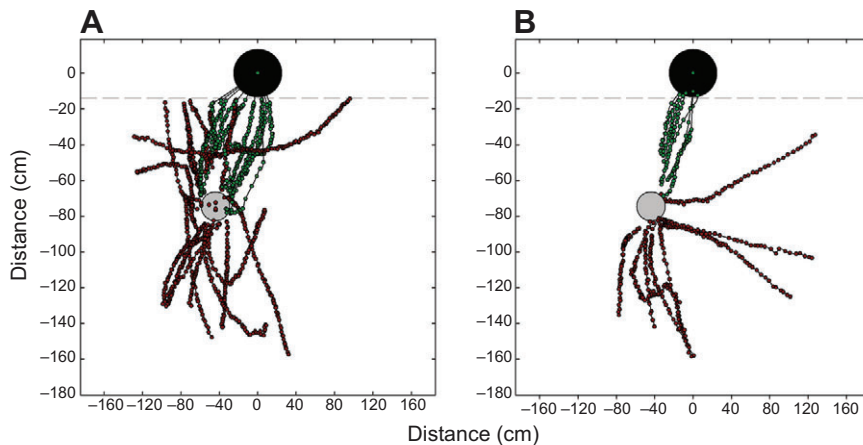

**Fig. 7. Phonotactic response pathways of reproductive female midshipman fish with ablated and sham-ablated lateral line systems.** Positive response pathways of females with ablated lateral line systems (A) and sham-ablated lateral line systems (B) are colored green and negative responses are colored red. The axes are the distance from the center of the tank (cm) where the monopole AQ 339 speaker (black circle) was located, and the dotted line represents the position of the opaque screen. Grey circles indicate the position of the plastic mesh cylinder where the animals were released.

alternatives is correct and to empirically assess utilization of the directional cues of acoustic pressure and radial particle velocity during sound source localization by midshipman and other fish.

### Contribution of the lateral line to sound source localization

Fish possess two mechanosensory systems, the ear and the lateral line, which respond to many of the same stimulus fields (e.g. Coombs et al., 1989; Schellart and Wubbels, 1998; Braun and Coombs, 2000). While early theorists suggested that the lateral line was sufficient for source localization in the near field, more recent studies demonstrate that vibrating dipole sources elicit physiological and behavioral responses mediated by both sensory systems, suggesting that either system may be sufficient for source localization (Van Bergeijk, 1967; Nauroth and Mogdans, 2009; Braun and Coombs, 2010; Coombs et al., 2010). Single-unit recordings from trunk lateral line afferents in plainfin midshipman demonstrate responses up to 100 Hz, showing that trunk SN are capable of encoding the 75–80 Hz stimulus used in the present experiments (Weeg and Bass, 2002). However, the question of whether the lateral line is required for localization behavior in this species had not been previously explored.

In our experiments, animals were released ~86 cm from an 80 Hz sound source, i.e. under near-field conditions in which both the inner ear and lateral line may be stimulated (e.g. Braun and Coombs, 2000). We observed no statistical difference in sound source localization by animals with sham-ablated lateral lines as compared with those where the lateral line was ablated with liquid N<sub>2</sub>. These data thus suggest that the lateral line is likely not required by this species for source localization in an axisymmetric sound field. Because we never achieved 100% ablation, it is theoretically possible that the remaining neuromasts were sufficient for localization behavior. We consider this hypothesis unlikely because ablation was usually successful over much of the animal, and the propensity for positive phonotaxis did not appear to be related to the proportion of surviving neuromasts (e.g. the animal with the greatest percentage of surviving neuromasts, 17.6%, failed to localize the source). Nonetheless, we cannot exclude the possibility that a few surviving neuromasts may be sufficient for source localization. Intact neuromasts were most commonly detected along the ventral mandible (see Table 1); thus, if the lateral line is used for localization, the mandibular SN could be involved. Other regions, such as the dorsal trunk line, would not appear to be necessary, given that 100% of dorsal trunk SN were ablated in some fish that demonstrated localization behavior (Table 1).

Interestingly, while females with ablated lateral lines demonstrated positive phonotactic responses, there was a significant difference in the mean orientation error (relative to the sound source) of the ablated versus sham-ablated fish. These results suggest a possible role for the lateral line in localization accuracy and imply complementary or synergistic roles for the lateral line and inner ear in source detection (e.g. Braun et al., 2002). Perhaps the lateral line is not indispensable for localization in this context, but is instead used to fine-tune the approach to the target. In the mottled sculpin (*Cottus bairdii*), the lateral line mediates orienting behavior to prey, and subtle differences in strike feeding were noted in two predatory fish species (muskellunge, *Esox masquinongy*, and largemouth bass, *Micropterus salmoides*) when the lateral line was inactivated with cobalt chloride (New and Kang, 2000; Coombs et al., 2001; Braun and Coombs, 2010). These studies provide behavioral evidence that the lateral line provides information important for orienting behaviors, consistent with the subtle differences in orientation to the sound source we observed in midshipman.

### Conclusions

In this study, the plainfin midshipman fish was used as a general model to investigate the use of swim bladder pressure cues and lateral line mechanosensory information in near-field sound source localization. Our findings suggest that pressure reception via the swim bladder is likely important while the lateral line system may not be required for sound source localization. Our results show that the midshipman can solve the 180 deg ambiguity in a complex field where the potential directional cues (phase relationship between pressure and particle motion) are the opposite to what they would be in a free field and suggest, therefore, that whatever strategy the female midshipman uses to correctly resolve the 180 deg ambiguity in our test tank or in the extremely shallow nesting environment would yield an incorrect resolution in a deep-water free-field environment. Therefore, the question of how fish use acoustic pressure cues to solve the 180 deg ambiguity of source direction from the particle motion vector remains unresolved.

### MATERIALS AND METHODS

#### Experimental animals

One hundred forty-six adult, reproductive female plainfin midshipman fish (*Porichthys notatus*) were collected during the summer midshipman reproductive season (May and June 2010). Fish were collected from the nests of Type I males (Sisneros et al., 2009) during the morning low tides in the intertidal zone of Tomales Bay near Marshall, CA, USA, which is the same geographical location used in previous studies (Zeddies et al., 2010; Zeddies et al., 2012). Gravid females were visually distinguishable from Type I and II males based on the distended appearance of the abdomen due to the presence of eggs (Bass, 1996; Bass et al., 1999). Collected fish were transported in coolers with aerated seawater from the field to the Bodega Marine Laboratory (BML) in Bodega Bay, CA, USA. At BML, the fish were maintained in large communal tanks at natural ambient temperatures (12–14°C) until later that night, when experiments were conducted. All experimental procedures were approved by the University of California Davis Institutional Animal Care and Use Committee.

#### Experimental tank and setup

All localization experiments were conducted at BML in an outdoor cylindrical concrete tank (4 m diameter, 0.75 m height), the same tank used in previous studies (McKibben and Bass, 1998; McKibben and Bass, 2001; Zeddies et al., 2010; Zeddies et al., 2012). A sound source (Lubell AQ339, Clark Synthesis, Littleton, CO, USA, or a US Navy J-9 transducer) was suspended in the center of the tank and positioned 10 cm above the tank floor. Note that two different sound sources were used for these experiments because the J-9 transducer was unavailable for the lateral line ablation experiments. When using the AQ339, it was positioned with its radiating face oriented vertically. When using the J-9, the face of the projector was positioned such that it was oriented away from the tank center. A 2.44 m opaque plastic tarp was placed immediately in front of, but not touching, the sound projector to prevent possible visual cues of the projector that might affect sound source localization behavior.

The acoustic playback signal consisted of a continuous tone that mimicked the fundamental frequency of the male advertisement call, as this stimulus elicits robust positive phonotaxis in gravid female plainfin midshipman fish (Bass et al., 1999; Bass and McKibben, 2003). The playback signal used was either 75 or 80 Hz, based on the ambient temperature of the water in the tank, as previous studies reported that female midshipman showed a temperature-dependent frequency preference in their phonotactic responses (McKibben and Bass, 1998). While temperature may also influence auditory sensitivity in some fish species (Wysocki et al., 2009), in the present experiment both control and experimental animals were tested on a given night using the same temperature parameters, allowing for comparisons between treatment groups. The acoustic playback stimuli were generated by an Agilent 33120A function generator and passed through a Krohn-Hite 3550 filter (30–500 Hz bandpass) to a power amplifier (Crown Audio Inc., Elkhart, IN, USA) that drove the sound projector. Acoustic

pressure levels were verified nightly prior to behavioral experiments by placing a hydrophone (model 8103, Brüel and Kjaer, Norcross, GA, USA, or model BM8178-7, Sonatech, Santa Barbara, CA, USA) at one of the two sites within the tank where fish would be released (Fig. 1). The tone level at the calibration site was set at 130 dB (re.  $1 \mu\text{Pa}$  peak), consistent with sound pressure levels of the advertisement calls recorded near the nests of Type I males (Bass and Clark, 2003).

The behavioral responses of female midshipman fish were recorded using a digital video recorder and a CV110 Precision black-and-white camera (0.2 lx minimum light level) mounted ~6 m above the outdoor test arena. The video recordings were digitized using a Vixia HV30 camcorder (Canon) and iMovie 7.0 software (Apple Inc., Cupertino, CA, USA). Windows Movie Maker 5.0 (Microsoft, Redmond, WA, USA) and SigmaScan Pro 5.0 (Systat Inc., Chicago, IL, USA) were used for frame-by-frame analysis of the digitized video records. Every fifth frame was analyzed by marking the position of the animal's head (on the midline between the two eyes) relative to the fixed position of the sound projector. The  $x$  and  $y$  coordinates of the animal's head were then used to track the movement of the animal in relation to the sound source and sound field.

### Acoustic measurements

In order to characterize the fields produced by the J-9 and AQ339 sound projectors, acoustic pressure and particle motion measurements were made following procedures described in previous studies (Zeddies et al., 2010; Zeddies et al., 2012). Pressures were measured using miniature hydrophones (Brüel & Kjaer model 8103), and particle motions were measured using a tri-axial accelerometer (PCB model W356A12; PCB Piezotronics, Inc., Depew, NY, USA) that was made neutrally buoyant by embedding it in syntactic foam. Sensor signals were conditioned (Brüel & Kjaer model 2692 and PCB Model 482A amplifier for the hydrophones and accelerometer, respectively), digitized and stored on a Windows-based computer. Using these sensors, the acoustic fields were mapped in a horizontal plane 1 cm below the source center. The scan region spanned the 'front' half of the test tank, where all midshipman sound exposure experiments were conducted.

### Experimental protocol

Sound playback experiments were conducted between 21:00 and 05:00 h during May and June 2010. Three red floodlights were positioned around the tank perimeter, which allowed for the observation and videotaping of the female midshipman phonotactic responses. The water temperature in the test tank ranged from 10 to 12°C and was controlled by adjusting the incoming flow rate of seawater to the tank prior to the behavioral tests. Before testing began each night, the water flow to the test tank was shut off and water depth was adjusted to 50 cm, a depth typical of natural nests in the field.

Female fish were held individually in 5 gallon (=18.93 l) buckets filled with water from the test tank for at least 10–15 min prior to testing. Tests began when an individual fish was placed in a 30 cm diameter plastic mesh cylinder at either release Site A or B inside the test tank, ~86.5 cm from the sound source (Fig. 1). Fish were placed in the cylinder while the acoustic stimulus was continuously playing (no acclimation period). Tests were terminated when the fish swam to the perimeter of the testing arena or after a positive phonotactic response. A positive response was defined as the point when a fish directly touched the speaker face and/or circled in front of or under the sound projector. Although the opaque plastic tarp visually obscured the position of the sound source suspended above the tank substrate, the fish was able to easily swim under the tarp in front of the speaker to reach the source during positive phonotaxis.

### Biased and unbiased release experiments

In most experiments, the mesh release cylinder was open at the bottom to allow the fish to swim in any direction at onset of the test. In some experiments, three quarters of the bottom circumference was closed off, leaving a window for the animals to exit that could be directed toward the sound source. This 'biased' release was used to determine whether midshipman fish were able to resolve the 180 deg ambiguity inherent in the particle motion vectors pointing toward (and away from) the sound source: fish able to detect the axis of particle motion but unable to resolve the

180 deg ambiguity would in some trials be expected to exit the cylinder away from the source in the unbiased (open) release experiments. Initial phonotaxis away from the source was physically impossible in the biased release experiments. Therefore, if fish were susceptible to the 180 deg ambiguity, 180 deg errors should have occurred at a higher rate given an unbiased release.

### Swim bladder deflation experiments

To investigate the necessity of the swim bladder for sound source localization, a group of female midshipman underwent surgical swim bladder deflation. Fish were first anesthetized by immersion in a 0.025% benzocaine (ethyl *p*-aminobenzoate) seawater bath until opercular movement ceased. After the animal was anesthetized, a small (5–8 mm) incision in the body wall was made followed by another small (5–6 mm) incision in the swim bladder that allowed the bladder to be deflated. Swim bladder deflation surgeries were performed on the day of animal collection, and completed 6 to 12 h before animals were used in behavioral experiments, which included a recovery time of at least 3–4 h before experiments were performed. Verification of the swim bladder deflation surgeries took place within 12 h (the next morning) of the behavioral experiments. 'Sham-deflated' control fish were anesthetized and a similar small (5–8 mm) incision was made in the body wall along the trunk of the fish just dorsal to the swim bladder at a position where the bioluminescent photophores are found on the body. Following surgery, fish were revived by flushing seawater over the gills until opercular movement resumed and the fish showed normal righting behavior.

### Lateral line ablation experiments

The lateral line was selectively ablated with liquid nitrogen. Fish were anesthetized with a 0.025% concentration of benzocaine until opercular movement ceased. Small stainless steel or copper wire probes were dipped in liquid  $\text{N}_2$  and applied to the head and body of the fish to specifically ablate the superficial neuromasts (SN) while the fish was under deep anesthesia. To ablate the canal neuromasts (CN), canals were first opened with microdissection scissors, then the liquid  $\text{N}_2$ -cooled probe was applied and the canals were re-sealed with super glue (cyanoacrylate). For sham-ablated controls, a subset of ventral photophores was selectively damaged with liquid  $\text{N}_2$  using a procedure otherwise comparable to the SN ablation technique. Sham-ablated fish were anesthetized for the same period of time as lateral-line-ablated animals. The entire ablation process lasted 30–45 min. Fish were then revived by flushing seawater over the gills until opercular movement resumed and the fish showed normal righting behavior.

Ablated fish were active upon recovery from anesthesia but did not show normal behavioral escape responses when gently stimulated with a water jet applied to the skin, suggesting that the lateral line was not functioning. We noted that deep anesthesia (fish left in benzocaine for a few minutes after opercular movement ceased) was preferable to shallow anesthesia (fish removed from benzocaine as soon as opercular movement ceased), as fish, after shallow anesthesia, did not swim normally in the hours after ablation, either in the recovery tank or in the sound localization test tank. Of the 50 animals that had ablated and sham-ablated lateral line treatment, 39 fish were tested on the same day of surgery while 11 fish were tested the day following surgery as a result of the lethargic swimming response after recovery. *Post hoc* assessment confirmed that the lateral line remained ablated in fish tested the day following the ablation procedure, i.e. lateral line hair cells had not regenerated in the intervening <30 h. The lethargic response observed in some animals tested shortly after the ablation procedure suggests a potential confounding effect of the benzocaine anesthesia and surgical ablation stress.

### Lateral line visualization

Ablation success was qualitatively verified in a subset of animals immediately after the behavioral localization experiment. Fish were immersed in 0.005% DASPEI [2-(4-(dimethylamino)styryl)-1-ethylpyridinium iodide; Life Technologies] in seawater for 15 min in order to visualize remaining neuromasts, rinsed in seawater, and anesthetized in a 0.025% benzocaine bath. Labeling was observed using a Nikon AZ100 stereomicroscope microscope equipped for epifluorescence and images were taken with a Coolsnap HQ2



camera (Photometrix) and NIS Elements software. After imaging, animals were euthanized with an overdose of benzocaine, weighed, measured and fixed in 4% paraformaldehyde for subsequent lateral line dissection and labeling with fluorescently tagged phalloidin.

Four regions of SN were selected for phalloidin labeling: a 2 cm region from the right dorsal line starting anterior to the dorsal fin, a 1 cm region on the top of the head (left side), 1.5–2 cm from the ventral line (left side) starting at the anterior end of the anal fin, and the entire caudal fin. Given the small number of CN in this species, all canals were dissected out of the head and labeled rather than selecting discrete CN regions for sub-sampling. Sampling regions for SN and CN are shown in Fig. 3. Dissected SN or CN were treated with  $20 \mu\text{g ml}^{-1}$  proteinase K for 30 min at  $37^\circ\text{C}$  to digest the cupula and increase phalloidin penetration. Samples were then incubated for 30–40 min in Oregon Green phalloidin (Life Technologies) diluted 1:100 in  $0.1 \text{ mol l}^{-1}$  phosphate-buffered saline (PBS), rinsed in fresh PBS, and mounted in 50% glycerol on bridged coverslips. Images were taken on an Olympus FV-1000 confocal microscope with associated Fluoview software. Confocal  $z$ -series were compressed into brightest-point projections with ImageJ.

After behavioral experiments, the majority of animals were labeled with vital dye for post-fixation visualization of the lateral line. These animals were immersed in  $3 \mu\text{mol l}^{-1}$  FM 1-43FX (Life Technologies) for 90 s, rinsed in salt water, and euthanized with an overdose of benzocaine. Fish were weighed, measured and then placed in 4% paraformaldehyde (in PBS) and stored at  $4^\circ\text{C}$ . Fixed fish were transported back to the University of Washington, rinsed in fresh PBS, and the labeled lateral line was visualized with a Leica MZFLIII stereomicroscope. Images were taken with a Leica DFC350FZ camera and associated Firecam software (v. 3.2).

The number of remaining SN in the FM 1-43FX-labeled animals was quantified in six distinct regions of each animal: the right dorsal lateral line adjacent to the dorsal fin, the SN cluster on the dorsal head surface (right side), the ventral line starting anterior to the pelvic fins and extending to just behind the left pectoral fin, the ventral-most line on the left operculum, the mandibular line, and the entire caudal fin (see Fig. 2). These regions were selected based on initial observations in DASPEI-labeled animals that our ablation procedure was highly effective in some lateral line areas (e.g. the dorsal surface of the head), while other areas were more difficult to access with the frozen probe and therefore contained more surviving neuromasts (e.g. the mandibular line).

### Data analysis

The effects of swim bladder deflation were analyzed using logistic regression. Phonotaxis responses were categorized as 1 (correct localization) or 0 (incorrect) and fit to a logit function using a maximum likelihood method (Menard, 2002). Logistic regression was also used to examine the effects of deflated swim bladders as compared with re-inflated and sham-deflated swim bladders. To analyze the movement of the fish, the difference angles of the bearing of the fish relative to the source and relative to the local sound field were determined. This was done by determining the position of the fish from the video record (at 150 ms intervals) and then calculating the fish's bearing between consecutive positional points. The difference angle relative to the source was the difference between the fish's bearing and the angle from the fish's position to the source and was calculated between each time step (150 ms) for all recorded behavioral tracks. The difference between the fish's bearing and the direction to the source was defined as the orientation error. Statistical analyses were performed to determine whether there were differences among the experimental groups in the difference angles at two specific points in the phonotaxis pathway: (1) at the initial movement out of the release point (as defined as the vector between the first observed position outside the release cylinder and the fifth observed position) and (2) at the midpoint between the release point and the speaker.

As a measure of performance, the vector strength ( $r$ ) of the difference angles was computed. Vector strength is a measure of directional tendency or consistency toward the source (Batchelet, 1981); more formally, it is the normalized length of the mean vector of the circular distribution of angles to the source (the vector for each fish is unity length with the angle to the source, or in line with the particle motion vector). If all directions are equally likely, the vector strength is zero, whereas if all fish move in the same

direction, the vector strength is 1.0. Difference angles were tested for uniformity using a Hodges–Ajne test (Zar, 1999), which tests the null hypothesis that these angles are randomly distributed. A significant  $P$ -value indicates a bias in the distribution of difference angles, i.e. the null hypothesis of equal (random) distribution is false. Differences between treatments were analyzed using a Watson–Williams test (the circular equivalent of a two-sample  $t$ -test) (Watson and Williams, 1956), which analyzes whether two vectors have the same mean direction. The  $P$ -values were Bonferroni corrected to  $\alpha=0.025$  to reflect the tests conducted at two points in the phonotaxis pathway. Though this test assumes that the data have an underlying von Mises unimodal distribution, the test is robust to deviations from this assumption (Zar, 1999). All tests were conducted using the circular statistics toolbox (Berens, 2009) for MATLAB version 2009b (MathWorks, Natick, MA, USA).

### APPENDIX

#### Resolving the 180 deg ambiguity

The field of a point monopole in a free-field is an archetype for the directionalization problem. It is the simplest possible case, yet one that occurs often in nature. It would be expected that any method that a fish might use to resolve the ambiguity would have to work for this case to be of general use. The mathematics can be simplified further by assuming that the signal is sinusoidal. This is a good approximation for the advertisement call of the midshipman and was exactly the case in our experiment. We focus here on the directionalization cues present in the stimulus, not on the algorithm employed by fish such as those proposed by Rogers et al. (Rogers et al., 1988) or Schuijff and Buwalda (Schuijff and Buwalda, 1975). Any proposed algorithm must exploit these cues. We assume, therefore, that the fish can detect both the acoustic particle velocity vector (relative to its own body axis) and the acoustic pressure. We also assume that the discrimination is to be made by simultaneously sensing both quantities at the same point in the water. For a sinusoidal signal, the only parameters that can be measured are the amplitude and phase of the two field quantities.

Consider a point monopole source, oscillating at angular frequency  $\omega$ , located at the origin of a spherical coordinate system. Using complex notation, the acoustic pressure at a distance  $r$  from the source is given by:

$$p(r, t) = \text{Re}[\hat{p}(r)e^{-i\omega t}] = \text{Re}\left[\hat{p}_0 \frac{r_0 e^{ikr}}{r} e^{-i\omega t}\right], \quad (\text{A1})$$

where  $\hat{p}(r)$  is the complex amplitude of the received acoustic pressure,  $\hat{p}_0$  is the complex source level of the source,  $k$  ( $=\omega/c$ ) is the wavenumber,  $r_0$  is some reference distance and  $\text{Re}$  denotes the real part of the complex quantity in brackets.

From Euler's equation, the acoustic particle velocity in the radial direction is given by:

$$v_r(r, t) = \text{Re}[\hat{v}_r(r)e^{-i\omega t}] = \text{Re}\left[\frac{\hat{p}_0}{\rho c} \left(1 + \frac{i}{kr}\right) \frac{r_0 e^{ikr}}{r} e^{-i\omega t}\right], \quad (\text{A2})$$

where  $\hat{v}_r(r)$  is the complex amplitude of the radial particle velocity and  $\rho$  and  $c$  are the density and speed of sound in water, respectively.

From Eqns A1 and A2, it is evident that the complex radial velocity is proportional to the complex acoustic pressure:

$$\hat{v}_r(r) = \left[\frac{1}{\rho c} \left(1 + \frac{i}{kr}\right)\right] \hat{p}(r). \quad (\text{A3})$$

The quantity in brackets is the acoustic admittance, the inverse of the acoustic impedance. The real part of the term in brackets is proportional to the component of the radial velocity that is in phase

with the pressure (the far-field component) and the second term is proportional to the component in quadrature with the pressure (the near-field component). The sign of the real part is certain but the sign of the imaginary part is actually unknown because it depends on the true phase of the source, which is unknown. This can be seen by noting that the sign of the imaginary term in Eqn A3 would be negative if an  $e^{i\omega t}$  time dependence was used rather than the  $e^{-i\omega t}$  time dependence that was used in Eqn A1.

The acoustic power density (intensity), which is given by  $\vec{I} = p\vec{v}$ , consists of a radiated term, which has a nonzero time average and a reactive part with a zero time average. The general expression for time-averaged radial intensity is given by:

$$\langle I_r \rangle = \frac{1}{2} \text{Re}[\hat{p}(r)\hat{v}_r(r)^*]. \quad (\text{A4})$$

Substituting the expression for radial particle velocity in Eqn A3 into Eqn A4, the radiated power for the free-field point monopole is given by:

$$\langle I_r \rangle = \frac{r_0^2}{2\rho c r^2} |\hat{p}_0|^2. \quad (\text{A5})$$

Note that  $\langle I_r \rangle$  is always positive, indicating power being radiated away from the source. Normalizing this quantity by the magnitude of  $I_r$ , we obtain a localization metric that we will designate by  $\Gamma(r)$ , which is given by:

$$\Gamma(r) = \frac{(kr)^2}{\sqrt{1+(kr)^2}}, \quad (\text{A6})$$

for the free-field point source, which always falls between 0 and +1, while for an arbitrary field:

$$\Gamma(r) = \frac{\text{Re}(\hat{p}(r)\hat{v}_r(r)^*)}{|\hat{p}(r)\hat{v}_r(r)|}, \quad (\text{A7})$$

which must fall somewhere between  $-1$  and  $+1$ , with positive values corresponding to a sound propagating in the positive  $r$  direction and negative values corresponding to sound propagating in the negative  $r$  direction. The discrimination between plus and minus becomes increasingly difficult as the value of  $\Gamma$  approaches 0.

The fish measures particle velocity in its own body-centered coordinate system. For simplicity, assume that the fish is oriented so that its rostral-caudal acoustic axis is aligned with a radial to the source. The measured particle velocity is:

$$\hat{v}_m(r) = \pm \hat{v}_r(r). \quad (\text{A8})$$

The sign ambiguity in Eqn A4, which reflects the 180 deg ambiguity, occurs because the positive rostral-caudal axis may be pointing towards or away from the source. If the positive direction for the measured particle velocity is toward the tail of the fish, then a positive sign in Eqn A4 corresponds to the fish being oriented with its head towards the source and a negative sign corresponds to the fish being oriented with its tail towards the source. Using this choice of sign, we obtain:

$$\Gamma_m(r) = \frac{\text{Re}(\hat{p}_m(r)\hat{v}_m(r)^*)}{|\hat{p}_m(r)\hat{v}_m(r)|}, \quad (\text{A9})$$

where  $\hat{p}_m(r)$  and  $\hat{v}_m(r)$  are measured (or modeled) values of pressure and particle velocity at a point  $r$ . There are many possible ways in which  $\Gamma_m(r)$  could be evaluated in practice.

In supplementary material Figs S1 and S2, we plot the metric  $\Gamma_m(r)$  at 80 Hz for five cases: (1) a point source located at  $r=0$ , (2)

the field as measured in the Bodega Bay tank, and cases based on the results from a ‘method of images’ propagation model (Jensen et al., 2011) in 0.5 m deep water with source and receiver located 0.05 m from the bottom with three acoustically fast bottom types: (3) gravel, (4) fine sand and (5) sandy silt, with sediment parameters derived from Hamilton (Hamilton, 1972). Supplementary material Fig. S1 gives the results out to 5 m from the source and supplementary material Fig. S2 gives the results out to 100 m from the source. It is clear from supplementary material Fig. S1 that if a fish responded correctly to a free-field source, it would respond in the wrong direction in the Bodega Bay tank. Propagation models for the nesting environment indicate that close to the source, a fish that would respond correctly to a free-field source would respond in the wrong direction for ranges from 1 cm out to 25–50 m from the source, depending on bottom type. At large ranges, the theory indicates that the fish would respond in the correct direction. This latter conclusion would be tempered by the fact that the pressure 100 m from the source is 60 dB lower than it is at 1 m and that the depth of the water is unlikely to remain at 0.5 m at that distance.

Because the female midshipman in fact responds in the correct direction in the tank and likely does so in the nesting environment as well, we conclude that she must either alter her localization method when seeking males or is unable to correctly resolve the 180 deg ambiguity in deep water.

#### Acknowledgements

We thank Andrew Bass and Margaret Marchaterre for field assistance and logistical support, Edwin Rubel for microscopy support, and the University of California Bodega Marine Laboratory, where these experiments were performed. We also thank two reviewers for feedback that greatly improved the manuscript.

#### Competing interests

The authors declare no competing financial interests.

#### Author contributions

A.B.C., D.G.Z., R.R.F., M.D.G., P.H.R. and J.A.S. conceived and designed the experiments. P.H.R. and M.D.G. are responsible for the analysis contained in the supplementary material. All authors collected and analyzed the data. All authors contributed to the draft and/or revision of this article.

#### Funding

This collaborative research was supported by the National Science Foundation (IOS-0642214 to J.A.S. and R.R.F.).

#### Supplementary material

Supplementary material available online at <http://jeb.biologists.org/lookup/suppl/doi:10.1242/jeb.093831/-DC1>

#### References

- Bass, A. (1992). Dimorphic male brains and alternative reproductive tactics in a vocalizing fish. *Trends Neurosci.* **15**, 139–145.
- Bass, A. H. (1996). Shaping brain sexuality. *Am. Sci.* **84**, 352–363.
- Bass, A. H. and Clark, C. W. (2003). The physical acoustics of underwater sound communication. In *Acoustic Communication* (ed. A. M. Simmons, R. R. Fay and A. N. Popper), pp. 1–64. New York, NY: Springer.
- Bass, A. H. and McKibben, J. R. (2003). Neural mechanisms and behaviors for acoustic communication in teleost fish. *Prog. Neurobiol.* **69**, 1–26.
- Bass, A. H., Bodnar, D. and Marchaterre, M. A. (1999). Complementary explanations for existing phenotypes in an acoustic communication system. In *The Design of Animal Communication* (ed. M. D. Hauser and M. Konishi), pp 493–514. Cambridge, MA: MIT Press.
- Batchelet, E. (1981). The Rayleigh test. In *Circular Statistics in Biology* (ed. E. Batchelet), pp. 54–58. New York, NY: Academic Press.
- Berens, P. (2009). CircStat: a Matlab toolbox for circular statistics. *J. Stat. Softw.* **31**, 1–21.
- Braun, C. B. and Coombs, S. (2000). The overlapping roles of the inner ear and lateral line: the active space of dipole source detection. *Phil. Trans. Soc. Lond. B* **355**, 1115–1119.
- Braun, C. B. and Coombs, S. (2010). Vibratory sources as compound stimuli for the octovalateralis systems: dissection of specific stimulation channels using multiple behavioral approaches. *J. Exp. Psychol.* **36**, 243–257.

- Braun, C. B., Coombs, S. and Fay, R. R. (2002). What is the nature of multisensory interaction between octavolateralis sub-systems? *Brain Behav. Evol.* **59**, 162-176.
- Chapman, C. J. and Hawkins, A. D. (1973). A field study of hearing in the cod, *Gadus morhua* L. *J. Comp. Physiol. A* **85**, 147-167.
- Coombs, S., Gömer, P. and Münz, H. (1989). *The Mechanosensory Lateral Line: Neurobiology and Evolution*. New York, NY: Springer-Verlag.
- Coombs, S., Braun, C. B. and Donovan, B. (2001). The orienting response of Lake Michigan mottled sculpin is mediated by canal neuromasts. *J. Exp. Biol.* **204**, 337-348.
- Coombs, S., Fay, R. R. and Elepfandt, A. (2010). Dipole source encoding and tracking by the goldfish auditory system. *J. Exp. Biol.* **213**, 3536-3547.
- De Vries, H. (1950). The mechanics of the labyrinth otoliths. *Acta Otolaryngol.* **38**, 262-273.
- Dijkgraaf, S. (1960). Hearing in bony fishes. *Proc. R. Soc. B* **152**, 51-54.
- Fay, R. R. (1984). The goldfish ear codes the axis of acoustic particle motion in three dimensions. *Science* **225**, 951-954.
- Fay, R. R. (2005). Sound source localization by fishes. In *Sound Source Localization* (ed. A. N. Popper and R. R. Fay RR), pp 36-66. New York, NY: Springer-Verlag.
- Fay, R. R. and Simmons, A. M. (1999) The sense of hearing in fish and amphibians. In *Comparative Hearing: Fish and Amphibians* (ed. R. R. Fay and A. N. Popper), pp 269-318. New York, NY: Springer-Verlag.
- Greene, C. W. (1899). The phosphorescent organs of the toadfish, *Porichthys notatus*. *J. Morphol.* **15**, 667-696.
- Hamilton, E. L. (1972). Compressional-wave attenuation in marine sediments. *Geophysics* **37**, 620-646.
- Harris, G. G. and Van Bergeijk, W. A. (1962). Evidence that the lateral line organ responds to near-field displacements of sound sources in water. *J. Acoust. Soc. Am.* **34**, 1831-1841.
- Hawkins, A. D. and Sand, O. (1977). Directional hearing in the median vertical plane by the cod. *J. Comp. Physiol.* **122**, 1-8.
- Jensen, F. B., Kuperman, W. A., Porter, M. B. and Schmidt, H. (2011). *Computational Ocean Acoustics*, 2nd edn. New York, NY: Springer.
- McKibben, J. R. and Bass, A. H. (1998). Behavioral assessment of acoustic parameters relevant to signal recognition and preference in a vocal fish. *J. Acoust. Soc. Am.* **104**, 3520-3533.
- McKibben, J. R. and Bass, A. H. (2001). Effects of temporal envelope modulation on acoustic signals in a vocal fish: harmonic and beat stimuli. *J. Acoust. Soc. Am.* **109**, 2934-2943.
- Menard, S. (2002). *Applied Logistic Regression Analysis*, 2nd edn (*Applications in the Social Sciences, 07-106*). Thousand Oaks, CA: Sage University.
- Nauroth, I. E. and Mogdans, J. (2009). Goldfish and oscars have comparable responsiveness to dipole stimuli. *Naturwissenschaften* **96**, 1401-1409.
- New, J. G. and Kang, P. Y. (2000). Multimodal sensory integration in the strike-feeding behaviour of predatory fishes. *Phil. Trans. Soc. Lond. B* **355**, 1321-1324.
- Rogers, P. H. and Zeddies, D. G. (2008) Multipole mechanisms for directional hearing in fish. In *Fish Bioacoustics* (ed. J. F. Webb, A. N. Popper, R. R. Fay), pp. 233-252. New York, NY: Springer-Verlag.
- Rogers, P. H., Popper, A. N., Hastings, M. C. and Sidel, W. M. (1988). Processing of acoustic signals in the auditory system of bony fish. *J. Acoust. Soc. Am.* **83**, 338-349.
- Schellart, N. A. M. and Wubbels, R. J. (1998). The auditory and mechanosensory lateral line system. In *The Physiology of Fishes*, 2nd edn (ed. D. H. Evans), pp. 283-299. Boca Raton, FL: CRC Press.
- Schuijff, A. (1975). Directional hearing of cod (*Gadus morhua*) under approximate free field conditions. *J. Comp. Physiol. A* **98**, 307-332.
- Schuijff, A. and Buwalda, R. J. A. (1975). On the mechanism of directional hearing in cod (*Gadus morhua*). *J. Comp. Physiol. A* **98**, 333-343.
- Schuijff, A. and Hawkins, A. D. (1983). Acoustic distance discrimination by the cod. *Nature* **302**, 143-144.
- Sisneros, J. A., Alderks, P. W., Leon, K. and Sniffen, B. (2009). Morphometric changes associated with the reproductive cycle and behaviour of the intertidal-nesting, male plainfin midshipman *Porichthys notatus*. *J. Fish Biol.* **74**, 18-36.
- Van Bergeijk, W. A. (1967). The evolution of vertebrate hearing. In *Contributions to Sensory Physiology* (ed. W. D. Neff), pp. 1-49. New York, NY: Academic Press.
- Watson, G. S. and Williams, E. J. (1956). On the construction of significance tests on the circle and the sphere. *Biometrika* **43**, 344-352.
- Webb, J. F., Montgomery, J. C. and Mogdans, J. (2008). Bioacoustics and the lateral line system of fishes. In *Fish Bioacoustics* (ed. J. F. Webb, A. N. Popper and R. R. Fay), pp 145-182. New York, NY: Springer-Verlag.
- Weeg, M. S. and Bass, A. H. (2002). Frequency response properties of lateral line superficial neuromasts in a vocal fish, with evidence for acoustic sensitivity. *J. Neurophysiol.* **88**, 1252-1262.
- Wysocki, L. E., Montey, K. and Popper, A. N. (2009). The influence of ambient temperature and thermal acclimation on hearing in a eurythermal and a stenothermal otophysan fish. *J. Exp. Biol.* **212**, 3091-3099.
- Zar, J. H. (1999). *Biostatistical Analysis*, 4th edn. Upper Saddle River, NJ: Prentice Hall.
- Zeddies, D. G., Fay, R. R., Alderks, P. W., Shaub, K. S. and Sisneros, J. A. (2010). Sound source localization by the plainfin midshipman fish, *Porichthys notatus*. *J. Acoust. Soc. Am.* **127**, 3104-3113.
- Zeddies, D. G., Fay, R. R., Gray, M. D., Alderks, P. W., Acob, A. and Sisneros, J. A. (2012). Local acoustic particle motion guides sound-source localization behavior in the plainfin midshipman fish, *Porichthys notatus*. *J. Exp. Biol.* **215**, 152-160.

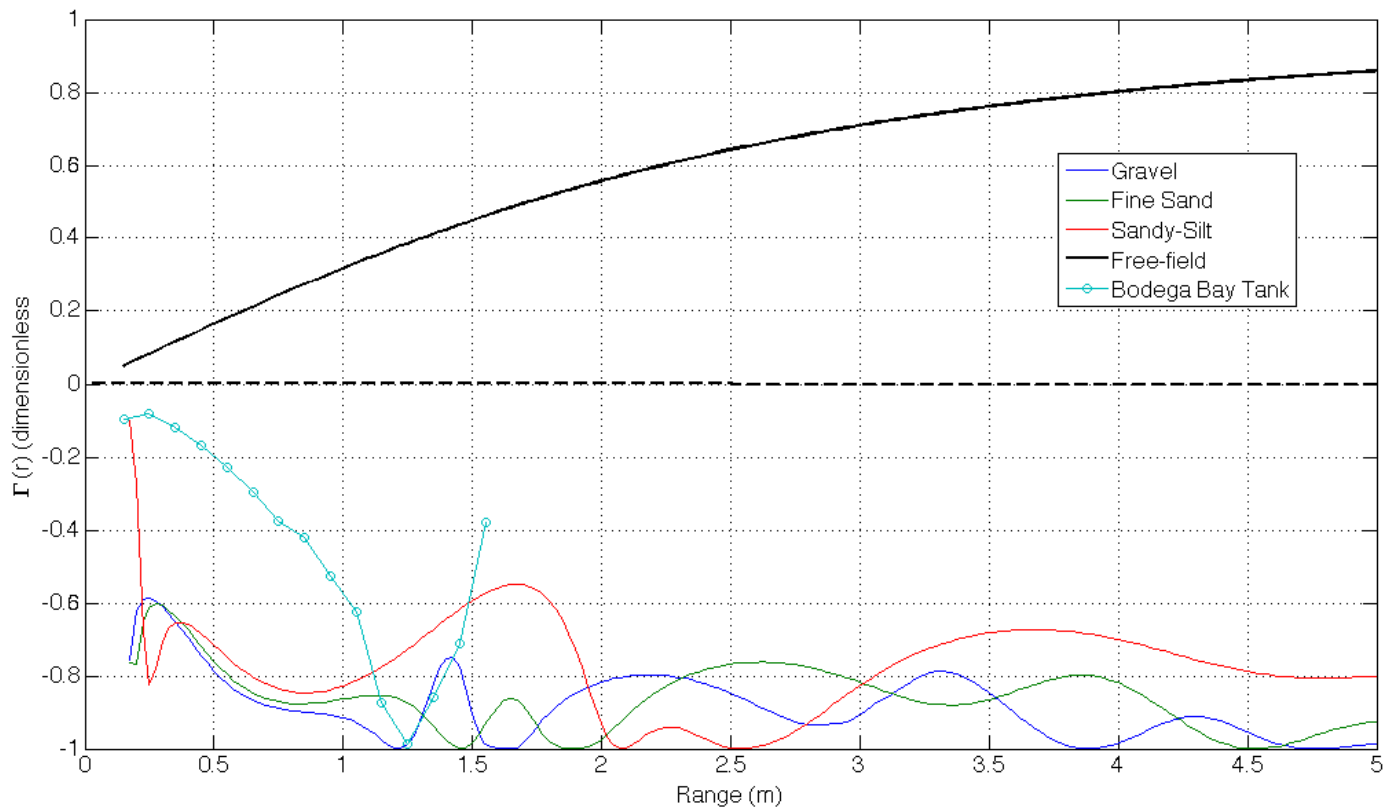

**Fig. S1.** Comparison of the localization metric  $\Gamma_m$ , at 80 Hz, as given in Eqn A9 (see Appendix), as a function of range out to 5 m from the source for a free-field point source (black), for the measured field in the Bodega Bay tank (cyan), and for modeled results for 0.5 m deep water, with source and receiver 0.05 m from the bottom, and with three different sediment types: gravel (blue), fine sand (green) and sandy silt (red). It would be expected that positive values for  $\Gamma_m$  would indicate the source to be located at  $r=0$  and negative values would indicate that the source is located in the opposite direction.

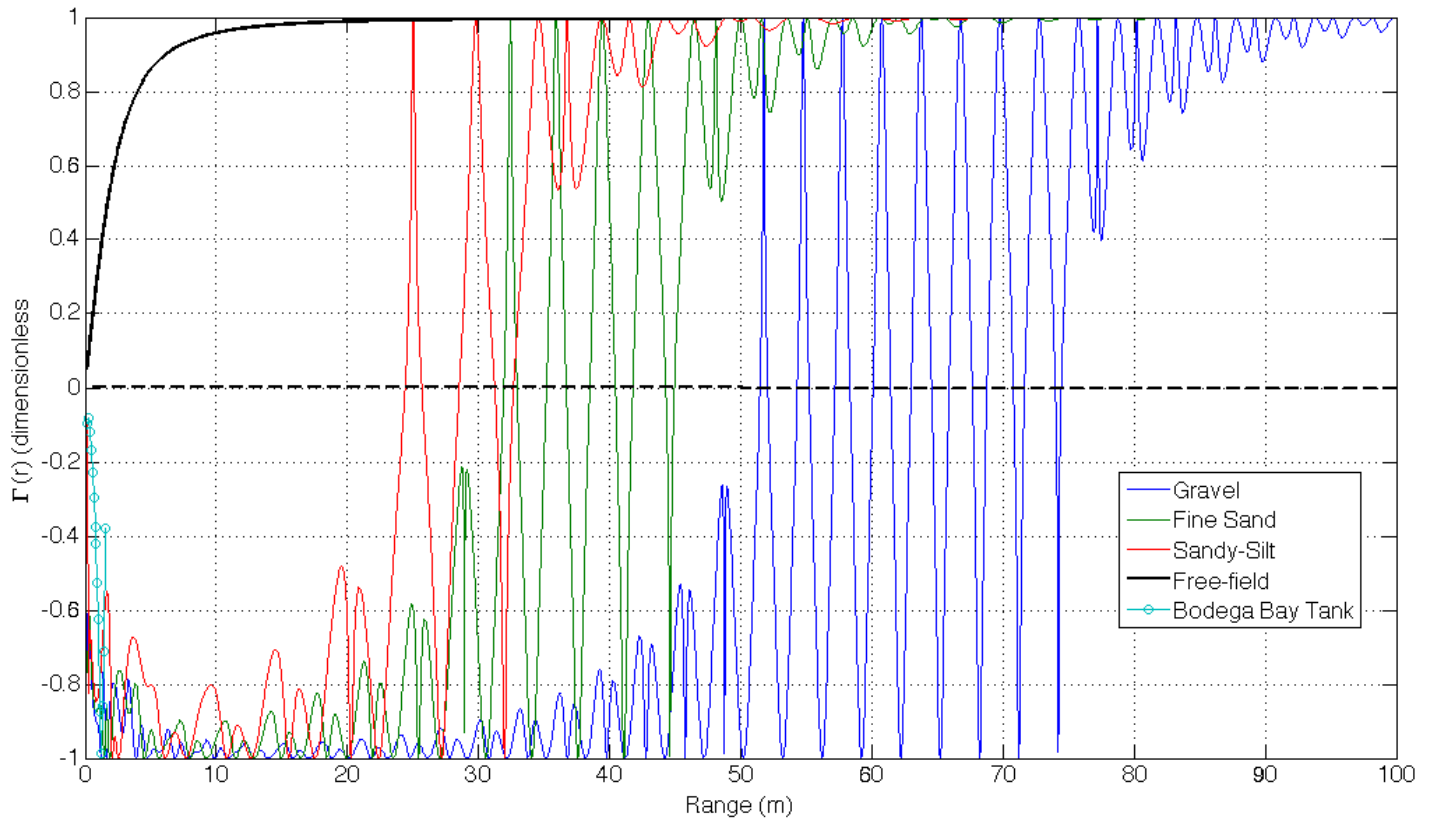

**Fig. S2.** Comparison of the localization metric  $\Gamma_m$ , at 80 Hz, as given in Eqn A9 (see Appendix), as a function of range out to 100 m from the source for a free-field point source (black), for the measured field in the Bodega Bay tank (cyan), and for modeled results for 0.5 m deep water, with source and receiver 0.05 m from the bottom, and with three different sediment types: gravel (blue), fine sand (green) and sandy silt (red). It would be expected that positive values for  $\Gamma$  would indicate the source to be located at  $r=0$  and negative values would indicate that the source is located in the opposite direction.